



WEB: www.yorkville.com

**WORLD HEADQUARTERS
CANADA**

Yorkville Sound
550 Granite Court
Pickering, Ontario
L1W-3Y8 CANADA

Voice: (905) 837-8481
Fax: (905) 837-8746

U.S.A.

Yorkville Sound Inc.
4625 Witmer Industrial Estate
Niagara Falls, New York
14305 USA

Voice: (716) 297-2920
Fax: (716) 297-3689



Quality and Innovation Since 1963
Printed in Canada



AP4040

PROFESSIONAL SERIES

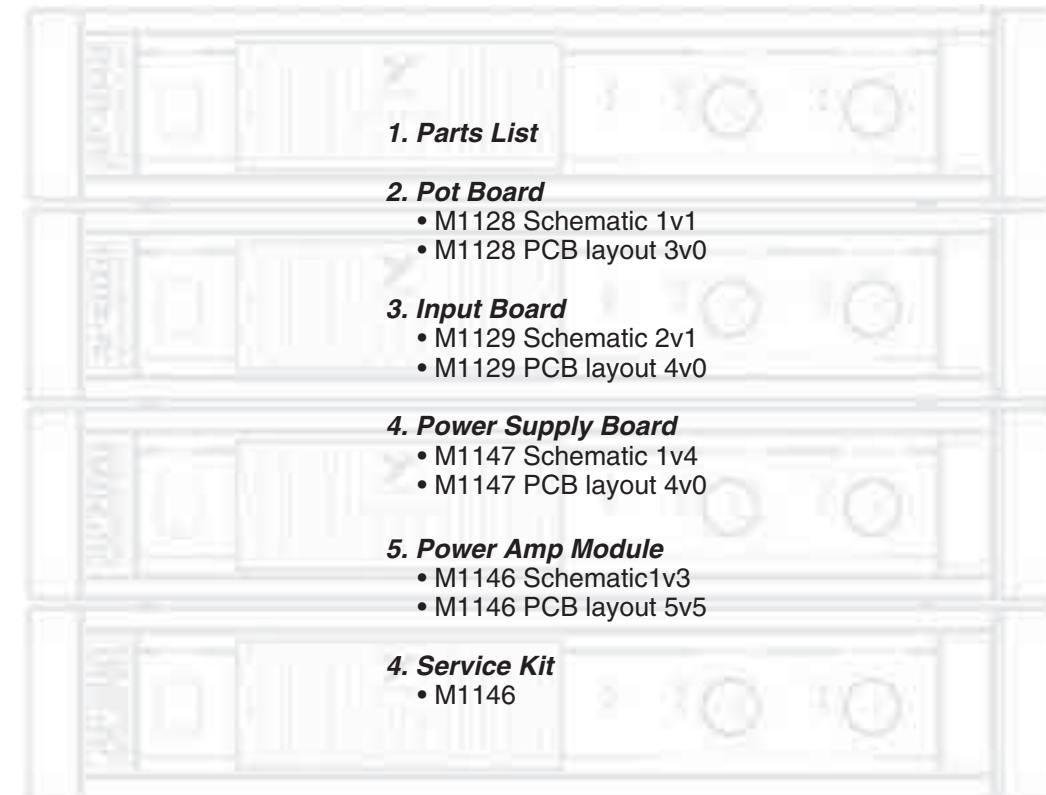

1. Parts List

2. Pot Board

- M1128 Schematic 1v1
- M1128 PCB layout 3v0

3. Input Board

- M1129 Schematic 2v1
- M1129 PCB layout 4v0

4. Power Supply Board

- M1147 Schematic 1v4
- M1147 PCB layout 4v0

5. Power Amp Module

- M1146 Schematic 1v3
- M1146 PCB layout 5v5

4. Service Kit

- M1146

MODEL TYPE: YS4040

SERVICE MANUAL

IMPORTANT SAFETY INSTRUCTIONS



INSTRUCTIONS PERTAINING TO A RISK OF FIRE, ELECTRIC SHOCK, OR INJURY TO PERSONS

CAUTION:

TO REDUCE THE RISK OF ELECTRIC SHOCK, DO NOT REMOVE COVER (OR BACK).

NO USER SERVICEABLE PARTS INSIDE.

REFER SERVICING TO QUALIFIED SERVICE PERSONNEL.

INSTRUCTIONS RELATIVES AU RISQUE DE FEU, CHOC ÉLECTRIQUE, OU BLESSURES AUX PERSONNES

AVIS:

AFIN DE REDUIRE LES RISQUE DE CHOC ELECTRIQUE, N'ENLEVEZ PAS LE COUVERT (OU LE PANNEAU ARRIERE)

NE CONTIENT AUCUNE PIECE REPARABLE PAR L'UTILISATEUR.

CONSULTEZ UN TECHNICIEN QUALIFIE POUR L'ENTRETIEN

Read Instructions

The Owner's Manual should be read and understood before operation of your unit. Please, save these instructions for future reference.

Packaging

Keep the box and packaging materials, in case the unit needs to be returned for service.

Warning

When using electric products, basic precautions should always be followed, including the following:

Power Sources

Your unit should be connected to a power source only of the voltage specified in the owners manual or as marked on the unit. This unit has a polarized plug. Do not use with an extension cord or receptacle unless the plug can be fully inserted. Precautions should be taken so that the grounding scheme on the unit is not defeated.

Hazards

Do not place this product on an unstable cart, stand, tripod, bracket or table. The product may fall, causing serious personal injury and serious damage to the product. Use only with cart, stand, tripod, bracket, or table recommended by the manufacturer or sold with the product. Follow the manufacturer's instructions when installing the product and use mounting accessories recommended by the manufacturer.

The apparatus should not be exposed to dripping or splashing water; no objects filled with liquids should be placed on the apparatus.

Terminals marked with the "lightning bolt" are hazardous live; the external wiring connected to these terminals require installation by an instructed person or the use of ready made leads or cords.

No naked flame sources, such as lighted candles, should be placed on the apparatus.

Power Cord

The AC supply cord should be routed so that it is unlikely that it will be damaged. If the AC supply cord is damaged DO NOT OPERATE THE UNIT.

Service

The unit should be serviced only by qualified service personnel.

Veillez Lire le Manuel

Il contient des informations qui devraient être comprises avant l'opération de votre appareil. Conservez S.V.P. ces instructions pour consultations ultérieures.

Emballage

Conservez la boîte au cas où l'appareil devait être retourner pour réparation.

Attention:

Lors de l'utilisation de produits électrique, assurez-vous d'adhérer à des précautions de bases incluant celle qui suivent:

Alimentation

L'appareil ne doit être branché qu'à une source d'alimentation correspondant au voltage spécifié dans le manuel ou tel qu'indiqué sur l'appareil. Cet appareil est équipé d'une prise d'alimentation polarisée. Ne pas utiliser cet appareil avec un cordon de raccordement à moins qu'il soit possible d'insérer complètement les trois lames. Des précautions doivent être prises afin d'éviter que le système de mise à la terre de l'appareil ne soit désengagé.

Risque

Ne pas placer cet appareil sur un chariot, un support, un trépied ou une table instables. L'appareil pourrait tomber et blesser quelqu'un ou subir des dommages importants. Utiliser seulement un chariot, un support, un trépied ou une table recommandés par le fabricant ou vendus avec le produit. Suivre les instructions du fabricant pour installer l'appareil et utiliser les accessoires recommandés par le fabricant.

Il convient de ne pas placer sur l'appareil de sources de flammes nues, telles que des bougies allumées.

L'appareil ne doit pas être exposé à des égouttements d'eau ou des éclaboussures et qu'aucun objet rempli de liquide tel que des vases ne doit être placé sur l'appareil.

Les dispositifs marqués d'une symbole "d'éclair" sont des parties dangereuses au toucher et que les câblages extérieurs connectés à ces dispositifs de connexion extérieure doivent être effectués par un opérateur formé ou en utilisant des cordons déjà préparés.

Cordon d'Alimentation

Évitez d'endommager le cordon d'alimentation. N'UTILISEZ PAS L'APPAREIL si le cordon d'alimentation est endommagé.

Service

Consultez un technicien qualifié pour l'entretien de votre appareil.

Yorkville AP4040 Power Amplifier**M1129 “THE INPUT BOARD”**

The input board processes the audio signal from the input jacks to the volume control board, (M1128).

Each channel consists of a balanced gain stage, switchable subsonic filter, and a stereo / mono / bridge switch.

Looking at the left channel, the balanced input, (XLR Jack) and unbalanced input (phone jack) are wired in parallel to the input of a balanced operational amplifier, (U4). The gain of this stage is 0.82 (-1.3dB) balanced and 1.6 (4.0dB) unbalanced. Resistors R25, R27 along with capacitors C11 and C12 form a radio interference elimination filter.

Switch S1 selects the cutoff frequency of the hi-pass subsonic filter. The subsonic filter provides a 20Hz or 40 Hz high pass filter. The filter consists of a tee network on the input of U3 along with R10, R28, C29 and C30, C33 and C34. The gain is 1 (0dB) in the passband, (above 100Hz).

The audio signals from the input board M1129 pass through the 14 conductor cable to board M1128.

M1128 “VOLUME CONTROL BOARD”**This board contains:**

- the front panel audio gain controls
- the front panel indicating LED's (power, protect, activity and clip).
- the audio limiters

Circuit Explanation:

- The left channel of the circuit is explained.

(Refer to the schematic of M1128 as the sections of the circuit are explained.)

The audio signal out of M1129 passes through volume control P2 and the desired level enters U2 through pin 6. U2 is set for a gain of 5 (14dB) when the volume control is in the fully clockwise position.

The AP4040's defeatable limiter is built around LD8. LD8 is an opto-resistive cell comprising of an LED that shines on a photocell. As the LED in the LD8 becomes brighter, the resistance of the photocell decreases, placing more of the audio signal on pin 5 (non-inverting input) of U2. This audio voltage gets subtracted from the signal on the inverting input and less signal appears on the output of U2. Transistors Q5 and Q6 along with the surrounding passive parts provide the attack and release time constants of the limiting function along with the drive currents for the clip LED and the LED inside LD8. When an audio signal on the output of the power amplifier section (on board M1146) enters clipping, pulses representing the duration of the clipped portion appear at LCLIP. These pulses turn on transistor Q6, and Q6 provides current pulses to turn on clip LED LD6. The pulses also pass through R7 and D6 to charge C3 and C36. When the voltage across C3 reaches 0.5 volts then Q5 turns on providing a current into the LED of the LD8 limiting the audio signal at U2. The charging (attack) and discharging (release) times of the limiter are 80mS and 3.5 seconds respectively. Resistors R50 and R7 provide the charging path, and resistor R51 provides the discharge path. The limiter can be defeated by placing the limiter switch (S2) in the in position which disconnects Q5 and the charging / discharging circuitry from V+.



550 Granite Court, Pickering, Ontario CANADA L1W-3Y8

4625 Witmer Industrial Estate, Niagara Falls, New York USA 14305

The activity LED circuit consists of Q1 and the surrounding circuitry. The audio signal enters the activity LED circuit through R2. R2 and C21 form a differentiator that turns Q1 on illuminating the activity LED whenever the audio signal increases in amplitude. A constant current flows through R55A, R55B and when Q1 is off, the collector current then flows through D1.

From M1128 the audio signal passes through a 12-conductor ribbon cable to circuit board M1147.

On M1127 an operational amplifier U201 re-references the ground for the audio signal from LREF or RREF to the corresponding LOG (left output ground) or ROG (right output ground). U201 also provides DC correction for DC offsets appearing on the output binding posts. Feedback from the output binding posts appears on LFNB or RFNB. Through R203A or R203B the DC offset achieves a gain of -1 from U201. The DC offset of opposite polarity on the output of U201 will compensate for the DC offset in the amplifier section on M1146 resulting in 0 volts DC on the output binding posts.

- The audio signal continues to M1146 via an 8-conductor ribbon cable.

M1126 “THE VOLTAGE AMPLIFIER AND CURRENT AMPLIFIER”**This board contains:**

- a voltage amplifier section
- a current amplifier section
- amplifier current limit section
- DC output protection
- heatsink temperature sensing

Voltage Amplifier Section

The voltage amplifier amplifies the audio signal's voltage from 6.8 volts peak (at the output of U201) to approximately 98v peak, which is required to drive the current amplifier section. The current amplifier provides the current required for the 98v peak signal to drive 1200 watts into 4 ohms out of the binding posts.

Before the circuit is described in detail here is a quick rundown on the signal's path through the voltage amplifier stage. Refer to the schematic of M1146. Let's consider that a positive going AC signal is present at the SIG input. The positive going signal will turn on the positive side of the voltage amplifier. The signal at the SIG input turns on Q12A (through R40A, D14A and D13A). The collector of Q12A pulls down on the base of Q14A turns this transistor on further and allows a greater current to flow out of Q14A's collector. This increase in current passes through Q15A and it's collector to emitter voltage decreases. The collector of Q15A now being more positive in voltage turns the base of Q18A on causing an increase in Q18A's collector current resulting in test point 1 going positive.

As the positive side of the amplifier was turning on the negative side would have been turning off. This is how test point 1 was able to move positive following the input signal. The reverse would hold true if a negative going signal were present on the input of the voltage amplifier.



550 Granite Court, Pickering, Ontario CANADA L1W-3Y8

4625 Witmer Industrial Estate, Niagara Falls, New York USA 14305

CIRCUIT DESCRIPTION:

The voltage amplifier is a mirrored image with circuitry connected to the positive power supply rail being identical (but opposite polarity) to the circuitry connected to the negative power supply rail.

For this reason we will look in detail at the positive side of the amplifier.

The audio signal enters the voltage amplifier at the SIG input. The signal passes through R40A, D14A and D13A to the base of Q12A. Diodes D13A and D14A set up the DC bias on Q12A to approximately 0.6 mA.

The first voltage gain stage consists of Q12A along with the resistor chain on its collector and the emitter resistor (R44A).

Transistor Q12A drives the base of Q14A through the resistor chain. A DC current of approximately 4 mA should flow through the collector of Q14A. The voltage drop across Q14A remains constant and is derived from the voltage drop across the voltage reference Q20A, resistor R58A, and the base/emitter junction of Q15A. This total voltage should equal approximately 3 VDC. Transistor Q14A is the second gain stage and its output current flows through Q15A. Transistor Q15A is a common base stage with the collector driving the base of output buffer Q18A.

Diode D17A is a clamping diode that prevents the maximum peak of the audio signal from coming within 4V of the 144 VDC rail. This is to prevent the output current amplifier from going into saturation during clipping and therefore having storage delay problems.

Transistor Q18A buffers the high impedance present on the collector of Q15A. The output of the buffer provides a low output impedance at the junction of R61A and R62A and is current limited to 30mA through the clamping action of D19A, D20A and D23A. The signal at the junction of R61A and R62A drives the succeeding current amplifier.

Current Amplifier Section

The current amplifier receives a high voltage audio signal from the voltage amplifier and provides the current drive necessary to drive speaker cabinets.

The current amplifier is a two-tier complimentary output driver design controlled by a complimentary darlington stage.

[CIRCUIT DESCRIPTION - REFER TO THE SIMPLIFIED SCHEMATIC #1 ON THE FOLLOWING PAGE]

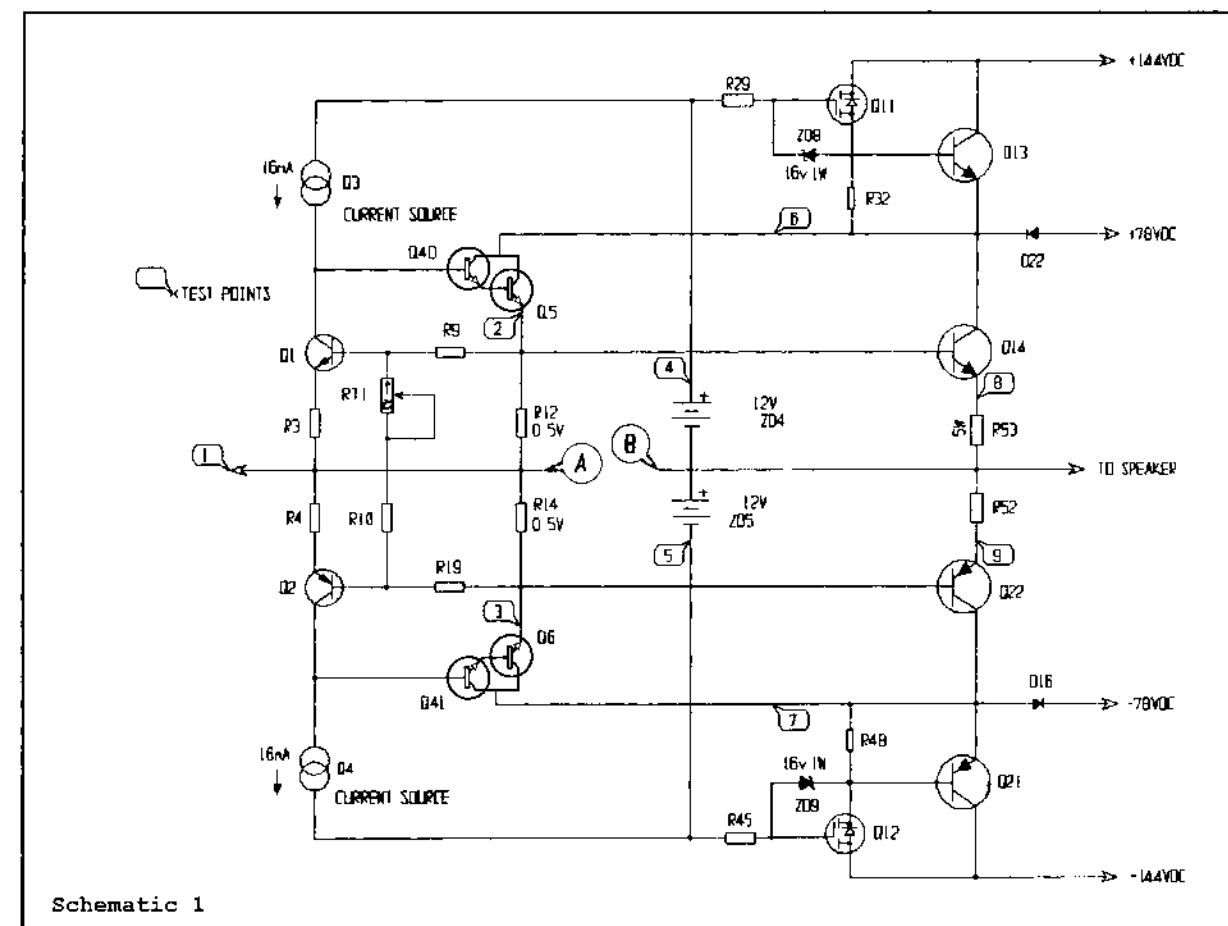

QUIESCENT CONDITION:

This design is class A/B and therefore the output driver transistors must be forward biased to provide low crossover distortion. In most class A/B designs, a diode chain or VBE multiplier is used to control the bias voltage and provide a means of adjusting the bias. This design is different, as there isn't a diode chain or VBE multiplier. For simplicity let's consider only the positive side of the current amplifier, that is all parts between the positive power supply rails and the audio signal output/input terminals. The negative side is the same as the positive, except for polarity changes.

To bias Q14, greater than 0.5V is needed from base to emitter, (or for simplicity from base to amplifier output). Points A and B are at the same potential, so consider them to be connected. If this is true then 0.5V from test point 2 to the amplifier output must appear across R12. There must be some way of developing this voltage across R12, and there is using the darlington (Q5 and Q40) driver along with local feedback.

Simplified schematic #1 shows the biasing circuit. The current needed to develop 0.5V across R12 comes from the emitter of Q5. When the amplifier is first turned on the current source (Q3) turns on Q5 and Q40 and current flows through R12 developing a voltage. When this voltage approaches 0.5V Q1 turns on and robs current from the base of Q40.



This causes Q40 to turn off until the reduced current flowing through Q5 maintains 0.5V across R12. Q1 will turn off slightly causing Q5 and Q40 to increase their collector currents. The circuit reaches a point of equilibrium with approximately 0.5V across R12.

Because all output devices are not identical and base emitter voltages vary, some adjustment must be available to slightly adjust the 0.5V across R12. This is accomplished with RT1. RT1 causes Q1 to turn on slightly more or less resulting in Q5 and Q40 turning on slightly more or less and therefore R12's voltage will be slightly more or less than 0.5v. The proper quiescent current voltage is 4mV (to be measured between test points 8 and 9).

The Second Tier and Tier Switching

Refer to the simplified schematic Fig. #1 while reading the following text. One way of making an amplifier more efficient is to vary the Power Supply Voltage on the collectors of the output transistors (Q14 & Q22). The lower the voltage from collector to emitter, the lower the device dissipation. During quiescent conditions, there is 55VDC on the collectors of output transistors Q14 and Q22. The peak AC voltage that can appear on the amplifier's output is approximately 139V peak. How can an output transistor deliver a 139V peak when its collector is only at 78VDC? It can if its collector is pulled up to 144VDC as the output signal's peak rises above 78VDC. Refer to Fig. #2. The second tier voltage must remain above the amplifier's output voltage by amount V_m . Therefore the circuitry controlling the second tier voltage must increase the tier voltage before the amplifier's output voltage reaches 78VDC. This leading voltage is necessary to compensate for time lag of the second tier circuit during fast rising amplifier output signals.

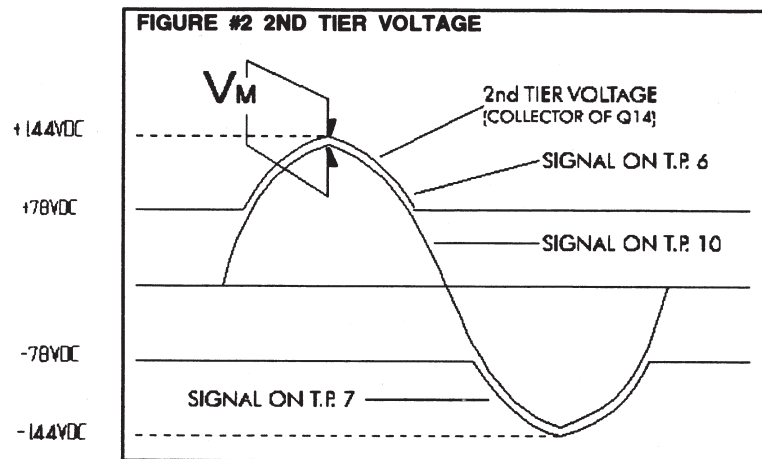

The voltage between the amplifier's output and test point 4 is approximately 12VDC derived from the voltage drop across ZD4. We call this voltage the "floating battery" because it floats on top of the output audio signal with test point 4 always being 12VDC greater than the peak of the output signal. Test point 4 drives the gate of mos-fet Q11. Q11 controls the transistors of the upper tier. As Q11 turns on its source forward biases the base of Q13 and Q13 pulls the collector of Q14 towards the 100 volt rail. The gate to source voltage needed to turn on Q11 is approximately 3.5 volts. When the peak output signal is about 69.5vp (78v-(12v-3.5v)) then Q11 will start to turn on the second tier. The second tier voltage will remain about 13 volts (V_m) above the peak of the output signal

to the point of clipping where this voltage is reduced to about 6 volts (measured driving an 8 ohm load). Zener ZD8 protects the gate source junction of Q11 and also provides a supply current path through R29 for the "floating battery".

NOTE: The Power supply voltages given are those when the amplifier is **not** driving a speaker load. This will allow yo to check the tier switching with the cover of the amplifier off and the amplifier, therefore, running cool.

Current Limit Protection Circuitry

To have an amplifier drive 3000 watts into practically any combination of speaker cabinets and know what is a safe load and what is not is a very difficult task. An extensive



550 Granite Court, Pickering, Ontario CANADA L1W-3Y8

4625 Witmer Industrial Estate, Niagara Falls, New York USA 14305

amount of time was spent on the current limit circuitry so that it may simulate the safe operating area of the output transistors (SOAR curve). No matter how reactive the load may be the phase shift that it presents, along with it's resistive component is used to set the output current limit of the output transistor stage.

Refer to the schematic of board M1146 while reading the following text. The current limit circuitry is a mirrored image with circuitry connected to the positive power supply rail being identical (but opposite polarity) to the circuitry connected to the negative power supply rail. For this reason we will look at the positive side of the circuitry.

Transistor Q9 measures the peak current flowing through resistor R53. The voltage across R53 (as a result of the current flowing through it) is scaled down by R55, R35, R35A, R36, R37, D7 and D11 these parts make up the safe operating area along with the time constants of C30, R34, C12 and R26. Fig. #3 shows a waveform of the current that passes through R52 and R53 when the output of the amplifier is shorted to ground. This can only be seen by using an oscilloscope to measure differentially across R52 and R53. The conditions of the measurement are contained on the diagram. During current limit when Q9 turns on it reduces the voltage across R42. R42 is in series with a 16 volt zener (ZD7) and is also in parallel with the junction of Q8. The current that flows through R20, ZD7, R42, and R22 normally saturates Q8. When Q9 reduces the voltage across ZD9 and R42 to below 16.6 volts, Q8 turns off allowing a charge to build up on C8 through resistors R24 and R25. If current limiting occurs for a long enough duration to allow C8 to charge to 1.2 volts then Q7 will turn on tripping the relay circuit on board M1147. As soon as the relay is tripped the audio signal will be turned off at the output of the voltage amplifiers and will remain off for about 5 seconds before the relay turns on and allows the audio signal to pass through the amplifier. If a current limit condition is still present then the whole cycle will occur again and repeat until the load conditions on the amplifier's output are safe for the amplifier. When a safe load appears the amplifier will automatically reset and drive that load (the speaker cabinet).

DC Protection

If a DC voltage greater than 8 volts appears on the output of the amplifier for more than 200 milliseconds then triac Q30 will turn on holding the output at ground potential. MBS4992 is a device that turns on at either + or - 8 volts DC.

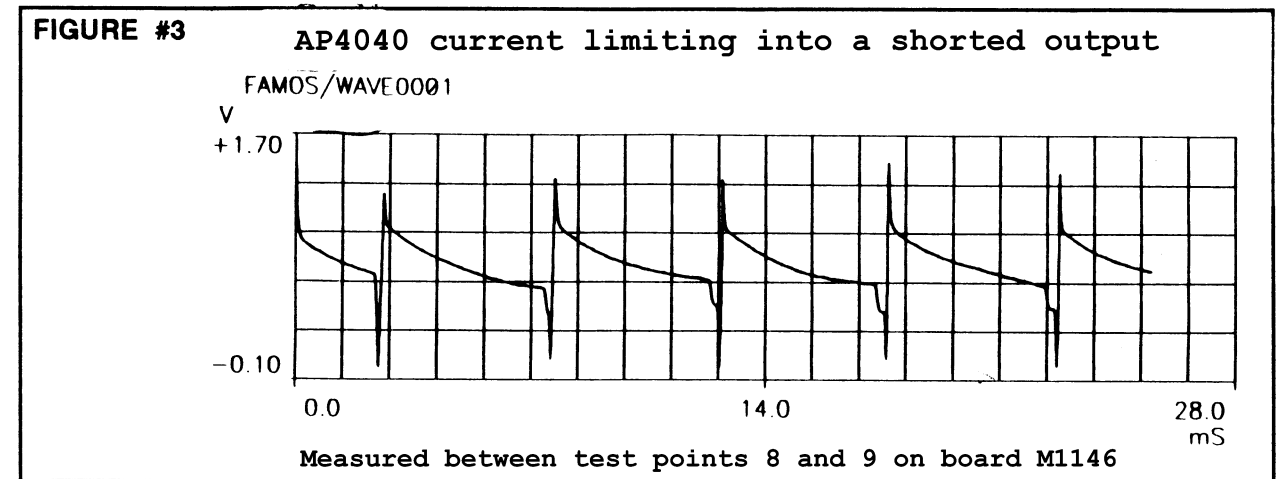

Measured between test points 8 and 9 on board M1146
FREQUENCY: 100Hz Y SCALE: 1 VOLT = 10 AMPS



550 Granite Court, Pickering, Ontario CANADA L1W-3Y8

4625 Witmer Industrial Estate, Niagara Falls, New York USA 14305

NOTE: Every time you replace blown output transistors on a M1146 board test the DC protection triac with the following circuit.

Conditions of test:

- A) Pass a 100Hz 25v peak signal through the M1126 board under test with no load connected to the amplifier output.
- B) Connect points 1 and 2 as shown in the diagram. The amplifier should go into protect mode as the triac (if working) shorted the output of the amplifier to ground, and the amplifier goes into current limit.
- C) Disconnect the triac test circuit and allow the amplifier to complete it's protect cycle.
- D) Reverse connections 1 to 2 and 2 to 1 and test again. The same results as in B) should be observed if the triac is working.

Only test the triac for one protect cycle as prolonged testing will heat the triac to a high temperature.

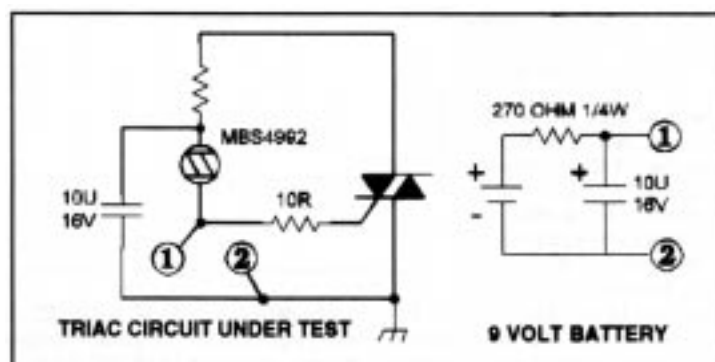

M1147 SHUTDOWN CIRCUIT, FAN CONTROL CIRCUIT, and SOFT TURN ON CIRCUIT:

- The shutdown relay and its associated drive circuitry have two possible operating states.
- Amplifier on under normal operating conditions.
- Amplifier power switch has just been turned OFF/ON, or the amplifier is in current limit protecting the amplifier's output transistors, or the amplifier has overheated.

Shutdown Circuit

Here is how the circuit accomplishes these functions. The relay's normally closed contacts short the output of the voltage amplifiers to ground when the power switch is off. When the power switch is turned on, the relay remains off (normally closed) for about 6 seconds. C203 charges to 35V and results in Q203 turning off allowing Q201 to turn on. As Q201 turns on, it connects the negative terminal of the relay's coil (Pin 16) to ground energizing the relay and opening the normally closed contacts.



550 Granite Court, Pickering, Ontario CANADA L1W-3Y8

4625 Witmer Industrial Estate, Niagara Falls, New York USA 14305

If prolonged current limiting occurs on the amplifier's output transistors then D204 or D205 (depending on which channel is current limiting) will be forward biased turning on Q202 (from its off state). Now +14VDC appears on the collector of Q202 and through R210 and R211 turn on Q203 therefore turning off Q201 by shorting its base emitter junction. Q201 turning off will turn the relay off and the normally closed contacts (off state) will short the outputs of the voltage amplifiers to ground so as not to continuously stress the amplifier's output transistors. A cycle now occurs. With the voltage amplifiers now disabled there is no signal driving the output transistors (Q13 to Q28).

The current limit circuit protecting the output transistors (Q13 to Q28) turns off and D204 and/or D205 are not forward biased and Q202 turns off. Through Q203 and Q201 the relay is turned back on and the voltage amplifiers are now active again, driving the output transistors. If current limiting still occurs, then the same cycle will occur. If the cause of current limiting (low impedance or short on the speaker output terminals) has been removed, then the amplifier will continue to operate normally.

The third operation that the relay provides is "overheat shutdown". If for some reason the fan cannot keep the heatsinks in a safe operating temperature area then the fan control circuit (on board M1147) will deliver through D207 a positive current to turn Q203 on and turn Q201 off to turn off the relay and disable the voltage amplifiers. When the fan has cooled down the temperature of the amplifier, then the signal through D207 will disappear and the relay circuit will turn on the relay to resume normal operation. Anytime the relay is in the "protect" mode (due to the abnormal states) then contact pin 4 of the relay will illuminate LD3 (the protect LED on the front panel).

Soft Turn On Circuit

To reduce the "inrush" current that flows through the line cord from the 120 VAC power source (typical with large linear power supplies), a circuit provides a soft turn on function. When the power switch is turned on, the current that initially flows through the primary of the transformer must flow through SG201 and SG202. These are surgeistors that reduce the peak inrush current flow. After about 500 milliseconds a relay's contacts short across the surgeistors so that they are not stressed by the current flowing through them under normal operation. A circuit consisting of Q240, Q241, C215, and the associated resistors provides the time delay for the turn on cycle of the relay. The circuit is very similar to the shutdown time delay circuit. Refer to the section on the shutdown circuit for a circuit description.

Fan Circuit

Looking at the schematic to board M1147, here is a quick explanation of the fan control circuit. There is a temperature sensor (AS35) on each M1146 board. When the amplifier is first turned on, Q207 and Q208 are off. The AS35 temperature sensors are configured as temperature controlled current sources. As either temperature sensor begins to heat up, more current flows through D212 or D218 increasing the voltage drop across R235 or R236. The hotter temperature sensor will provide more current than the cooler sensor and therefore develop a higher voltage across it's associated 8K2 resistor. The higher voltage will forward bias D212 or D218 reverse biasing the cooler temperature sensor's diode so that the hotter sensor will control the fan speed. At 40 degrees C there

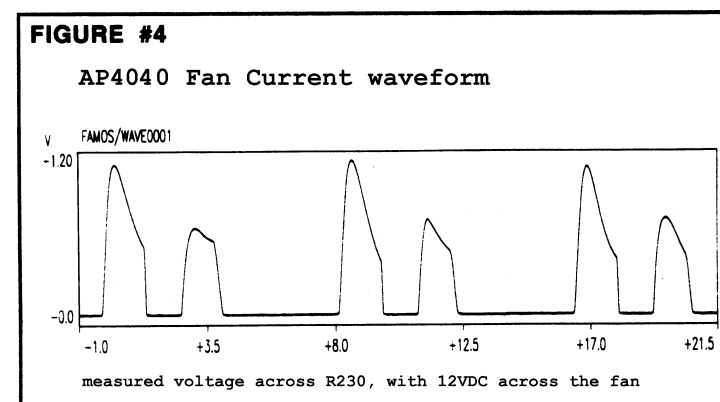

sensor's diode so that the hotter sensor will control the fan speed. At 40 degrees C there



550 Granite Court, Pickering, Ontario CANADA L1W-3Y8

4625 Witmer Industrial Estate, Niagara Falls, New York USA 14305

is 10 volts across R235 or R236 which is enough to turn on Q210, Q208, and Q207 providing 7 DC volts to the fan. Further heating the temperature sensors results in a larger DC voltage across the fan. To lower the dissipation of Q207, D215, D216, ZD205, ZD206 and R226 turn off Q207 and Q208 when the full wave rectified voltage present of the collector of Q207 reaches approximately 58V by robbing current from the base of Q208. The maximum fan voltage is 20.5 VDC. ZD207 and R228, R229 and R230 provide a current limiting function. Figure #4 shows the current through these resistors when there is 12VDC across the fan.

Thermal Shutdown Circuit

The emitter of Q210 in the fan circuit is the measuring point for the shutdown voltage. As the temperature sensing devices (AS35) that control the fan circuit heat up the voltage on the emitter of Q210 rises until at 85 degrees Celsius on the M1146 heatsinks. The voltage on the emitter of Q210 reaches 18 (85 degrees C) VDC and the amplifier must be shutdown to protect the output power transistors. ZD202 and D207 become forward biased and Q203 turns on turning the relay off and muting the audio signal. After the amplifier cools down the voltage will decrease until Q37 turns off turning the relay back on enabling the amplifier.

Identifying Defective Boards in the AP4040

STEP 1: VISUAL INSPECTION OF FRONT PANEL AND FAN

- Check to see whether the green power LED is lit. If not, the amplifier has a power supply (M1147 board), transformer, A.C. switch or line cord problem.
- If the red protect LED stays on or samples off and on, this usually indicates a problem with the voltage amplifier or current amplifier sections on one or both of the M1126 boards. Check for misaligned pin connections or see if the ribbon cables have been cut or pinched through their insulation.
- If the fan is running at full speed at power up this usually indicates a problem with the fan circuitry on the M1147 board, but it can also be caused by M1146 circuit problems. A damaged AS35 temperature sensor located under the M1146 heatsinks can cause erratic fan behavior.
- No output on either or both channels could be caused by intermittent push switches on the input board.

STEP 2: VISUAL INSPECTION OF INTERNAL CHASSIS AND INITIAL TESTING

After removing the lid, look for any signs of smoke, charring or burnt components. Before powering up replace the burnt components, and check the associated circuitry for damaged parts. Disconnect one M1127 board and test one board at a time to reduce the possibility of further damage. Use a variac to slowly increase the 120 VAC up from 0 volts while monitoring the quiescent current with a meter and the speaker output with an oscilloscope. Watch the speaker output for large DC offsets, or oscillation. Watch the meter for large collector currents flowing. Remember under quiescent conditions, there should only be 3 to 5 millivolts across test points 8 and 9 on the output stage of the amplifier.



550 Granite Court, Pickering, Ontario CANADA L1W-3Y8

4625 Witmer Industrial Estate, Niagara Falls, New York USA 14305

SPECIFICATIONS

Frequency Response:	+/- 1dB, 20 Hz to 20 KHz
Hum and Noise:	-103 dB below max output RMS voltage, unweighted
THD (1 khz, 4-Ohms):	<0.01%
THD(20Hz – 20kHz, 4-Ohms):	<0.1%
High Pass Filter:	40Hz, 12 dB/octave
Slew Rate:	Power amp section: 25 V/uS, 50 V/uS in bridged mode
Damping Factor:	> 600, 20 Hz - 20 KHz, into 8 ohms
Crosstalk:	-75 dB below full output at 1khz, -60 dB below full output (20 Hz - 20 KHz)
Input Impedance:	20 KOhms balanced, 10 KOhms unbalanced
Input Sensitivity:	1.4 VRMS sine wave (AP4020: 36 dB, AP4040: 39 dB gain)
Rejection:	CMRR@60Hz: minimum 48dB, typical 56dB
Controls:	Rotary GAIN controls, MONO/STEREO/BRIDGE, FILTER and LIMITER switches
Displays:	2x CLIP, 2x ACTIVITY, PROTECT, POWER ON (LEDS)
Input Connectors:	2x XLR, 2x 1/4" phone (TRS)
Output Connectors:	2x Binding Post, 3x Speakon™ SP-4
Turn On/Off transients:	< 15 milliwatt / seconds, 0.5 Wpk. (1s on delay)
Power Consumption:	Typ 1130, Max 1800 Watts
Transformer:	Toroidal
Protection:	Fully protected: DC, LOAD and THERMAL
Cooling:	Aluminum Heatsinks with DC servo-controlled fan (in front, out rear)
Size:	(DWH) 44 cm x 48 cm x 9 cm (front panel to binding posts) (DWH) 17.5 in x 19 in x 3.5 in Two rack spaces
Weight:	43.5 pounds, 19.8 Kilograms



550 Granite Court, Pickering, Ontario CANADA L1W-3Y8

4625 Witmer Industrial Estate, Niagara Falls, New York USA 14305

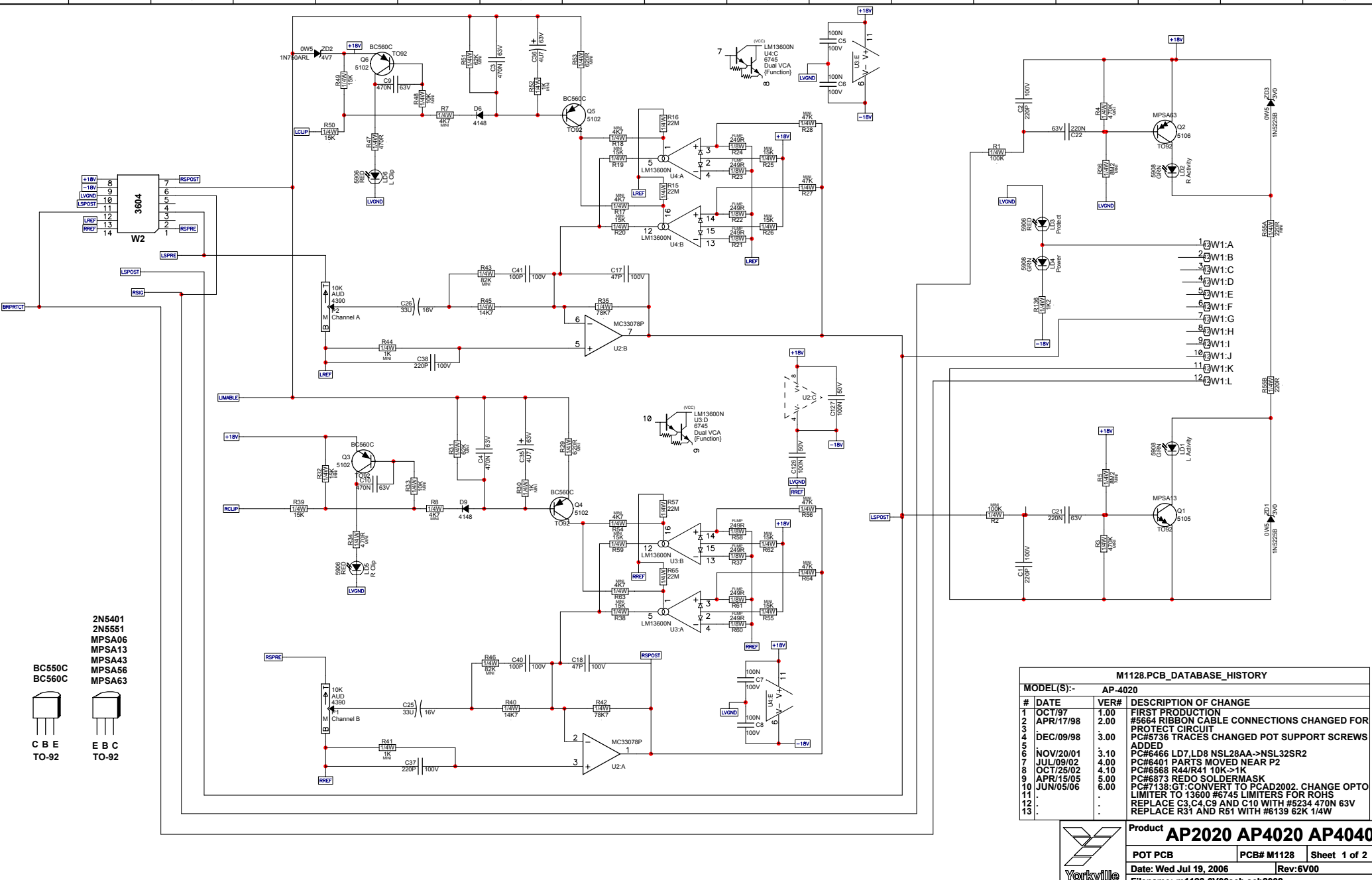

2N5401
2N5551
MPSA06
MPSA13
MPSA43
MPSA56
MPSA63



C B E
TO-92



E B C
TO-92

M1128.PCB_DATABASE_HISTORY		
MODEL(S):- AP-4020		
#	DATE	DESCRIPTION OF CHANGE
1	OCT/97	1.00 FIRST PRODUCTION
2	APR/17/98	2.00 #5664 RIBBON CABLE CONNECTIONS CHANGED FOR PROTECT CIRCUIT
3	DEC/09/98	3.00 PC#5736 TRACES CHANGED TO SUPPORT SCREWS ADDED
4		
5		
6	NOV/20/01	3.10 PC#6466 LD7.LD8 NSL28AA->NSL32SR2
7	JUL/09/02	4.00 PC#6401 PARTS MOVED NEAR P2
8	OCT/25/02	4.10 PC#6568 R44/R41 10K->1K
9	APR/15/05	5.00 PC#6873 REDO SOLDERMASK
10	JUN/05/06	6.00 PC#7138:GT:CONVERT TO PCAD2002. CHANGE OPTO LIMITER TO 13600 #6745 LIMITERS FOR ROHS
11	.	.
12	.	.
13	.	REPLACE C3, C4, C9 AND C10 WITH #5234 470N 63V REPLACE R31 AND R51 WITH #6139 62K 1/4W



Product **AP2020 AP4020 AP4040**
 POT PCB PCB# M1128 Sheet 1 of 2
 Date: Wed Jul 19, 2006 Rev:6V00
 Filename: m1128-6V00sch.sch2002

Bottom M1128 6V00

Pcb Mech M1128 6V00

Top Assy M1128 6V00

BlankSize - 13850x10000

ETCH GUIDE

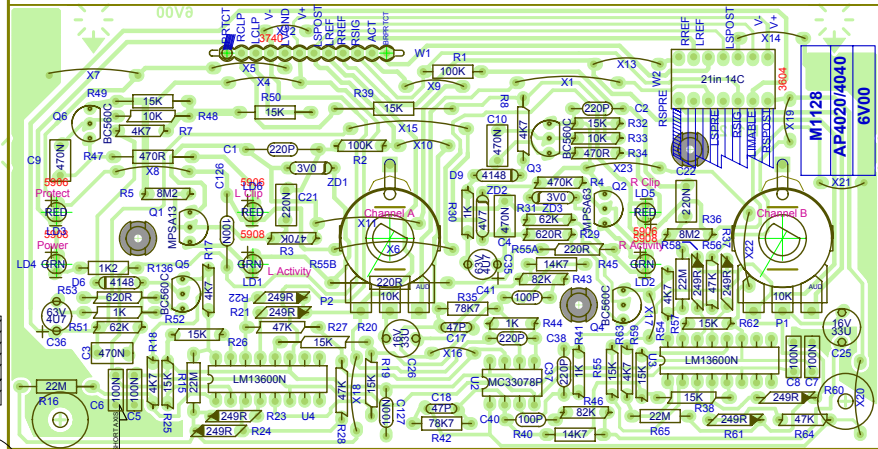

M1128 AP4020/4040 6V00



ETCH GUIDE

BlankSize - 13850x10000
StepAndRepeat - X2@6.875Y3@3.000

SEE LAYOUT DOCUMENTATION

M1128.PCB_DATABASE_HISTORY



SEE LAYOUT DIAGRAM



PRODUCTION NOTES

MODEL(S):- AP-4020

#	DATE	VER#	DESCRIPTION OF CHANGE
1	OCT/97	1.00	FIRST PRODUCTION
2	APR/17/98	2.00	#5664 RIBBON CABLE CONNECTIONS CHANGED FOR PROTECT CIRCUIT
3	.	.	.
4	DEC/09/98	3.00	PC#5736 TRACES CHANGED POT SUPPORT SCREWS ADDED
5	.	.	.
6	NOV/20/01	3.10	PC#6466 LD7,LD8 NSL28AA->NSL32SR2
7	JUL/09/02	4.00	PC#6401 PARTS MOVED NEAR P2
8	OCT/25/02	4.10	PC#6568 R44/R41 10K->1K
9	APR/15/05	5.00	PC#6873 REDO SOLDERMASK
10	JUN/05/06	6.00	PC#7138:GT:CONVERT TO PCAD2002. CHANGE OPTO LIMITER TO 13600 #6745 LIMITERS FOR ROHS
11	.	.	REPLACE C3,C4,C9 AND C10 WITH #5234 470N 63V
12	.	.	REPLACE R31 AND R51 WITH #6139 62K 1/4W
13	.	.	.

1	.	.	REPLACE R4 WITH #6127 470K 1/4W
2	D	V	N
3	D	V	N
4	D	V	N
5	D	V	N
6	D	V	N
7	D	V	N
8	D	V	N
9	D	V	N
10	D	V	N
11	D	V	N
12	D	V	N
13	D	V	N

M1128 DRILL HISTORY

MODEL(S):- AP-4020

#	DATE	VER#	DESCRIPTION OF CHANGE
1	JUL/09/02	V04	OLD PCAD LAST RELEASE
2	JUN/05/06	V05	NEW PCAD - SEE HISTORY TABLE
3	D	V	N
4	D	V	N
5	D	V	N
6	D	V	N

M1128 PENDING CHANGES

MODEL(S):- AP-4020

#	PC#	PENDING CHANGE
1	PC	X
2	PC	X
3	PC	X
4	PC	X
5	PC	X
6	PC	X

*PLACE IMPLEMENTED CHANGES INTO BOARD HISTORY

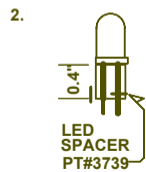
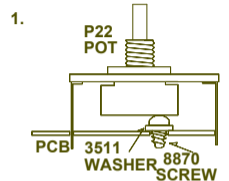

LEAD/PIN REFERENCE

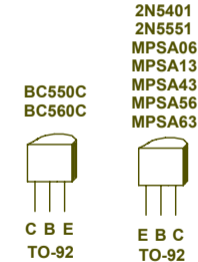

- 2N5401
- 2N5551
- MPSA06
- MPSA13
- MPSA43
- MPSA56
- MPSA63

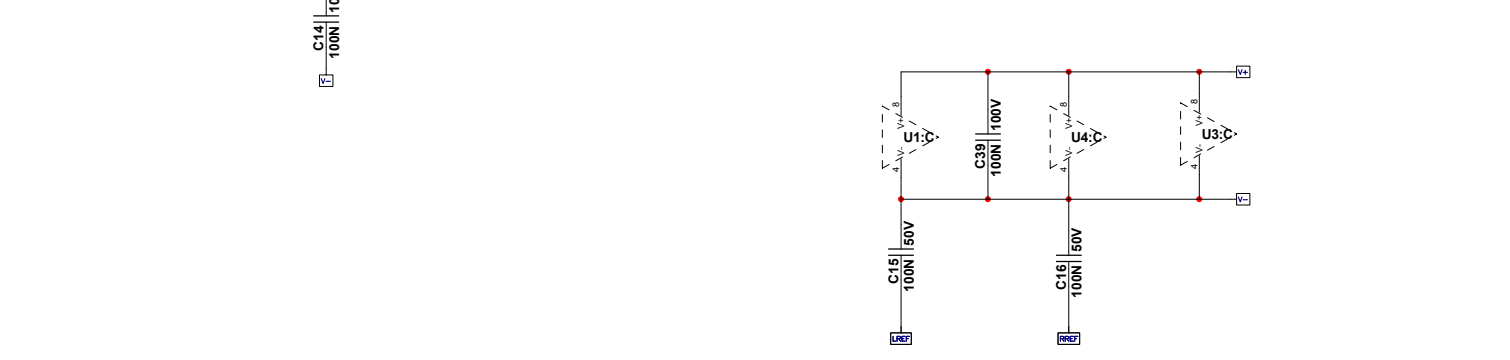
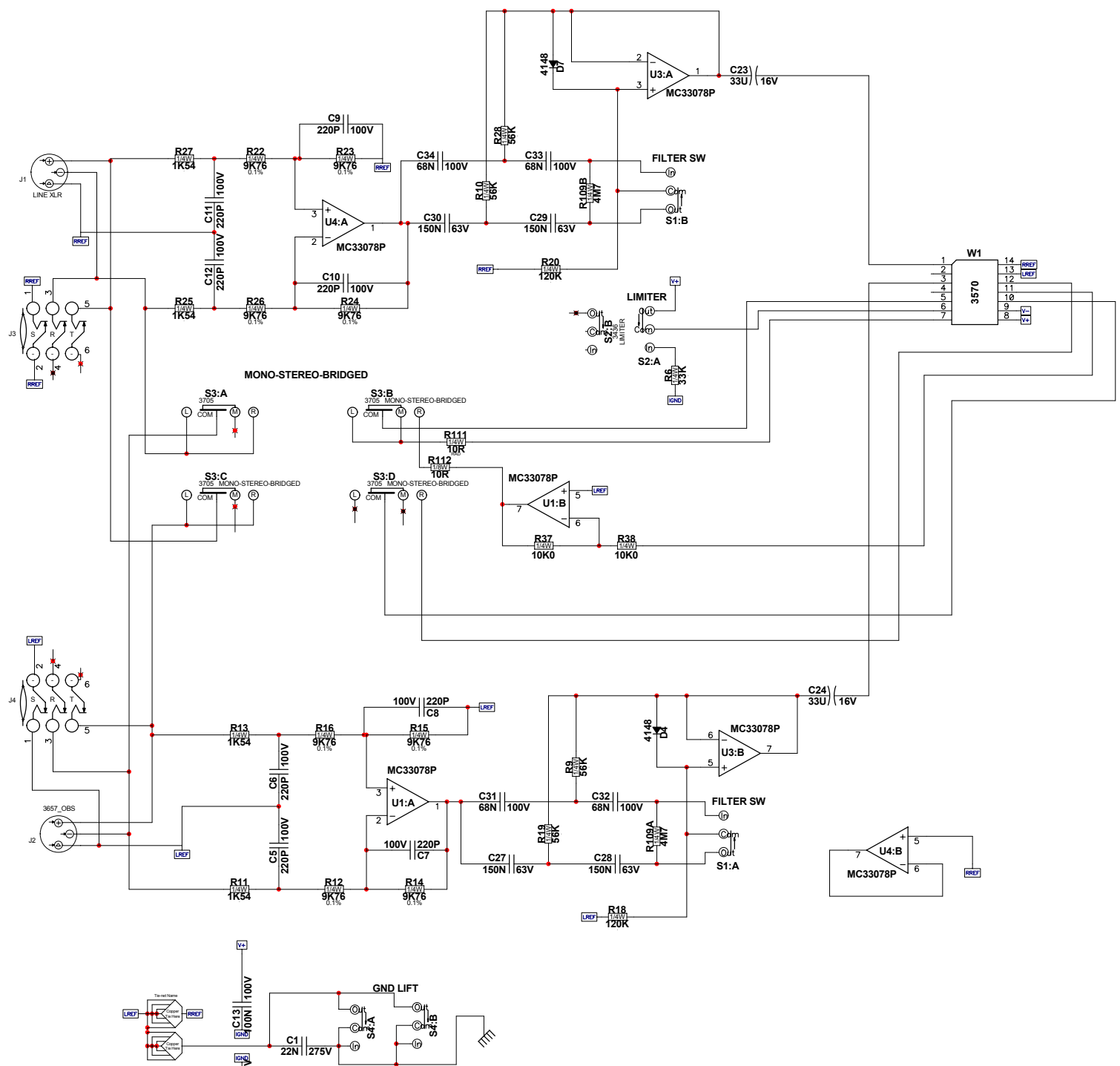

M1129 Database History			
MODEL(S):- AP2020 AP4040 AM1CE			
#	DATE	VER#	DESCRIPTION OF CHANGE
1	OCT/97	1.00	FIRST PRODUCTION
2	NOV/97	2.00	SWITCH NETS RREF AND RSPRE WITH LSPRE AT 14 PIN CONNECTOR. INPUT TO NONINVERTING
3			CHANGE C27, C29, C28, C30 TO 150N
4	DEC/02/97		ISOLATE PIN OF S3
5	APR/16/98	3.00	PC#5694 PINS 10-12 OF MC2 CONNECTED TO BRG SWT
6	JUL/01/98	4.00	PC#5694 ADD NETS BRPRCT, LVGN28 TO BRG SW
7	SEP/06/01	4.10	PC#6436 REPLACE R119 (10K) WITH JUMPER X119
8	APR/15/05	5.00	PC#6873 REDO SOLDERMASK
9	JUL/2005	6.00	CONVERT TO PCAD2002, PC#6944:ROUTE GAUGE, PC#6914:ADD TARGETS
10	AUG-15-2005		
11	D	V	N
12	D	V	N
13	D	V	N

M1129.sch_schematic-DATABASE_HISTORY			
MODEL(S):- AP4020 / AP4040 / AP2020 / AM1CE			
#	DATE	VER#	DESCRIPTION OF CHANGE
1	OCT/1997	1.00	FIRST PRODUCTION
2	NOV/12/97	2.00	REVERSED INPUT POLARITY. MODIFIED FOR AP2020
3	DEC/02/97		C27, C28, C29, C30 TO 150n
4	APR/22/98	2.10	PC#5694 ADD NETS BRPRCT, LVGN28 TO BRG SW
5	SEP/06/01	2.20	DELETE R119
6	JUL/2005	3.00	CONVERT TO PCAD2002
7	D	V	N
8	D	V	N
9	D	V	N
10	D	V	N
11	D	V	N
12	D	V	N
13	D	V	N

Product {Drawing Number}

{Title} PCB# M1129 Sheet 1 of 2

Date: Tue May 02, 2006 Rev: v6.00

Filename: M1129-6v00.sch2002



Top Assy M1129 v6.00

ETCH GUIDE

Pcb Mech M1129 v6.00

Bottom M1129 v6.00

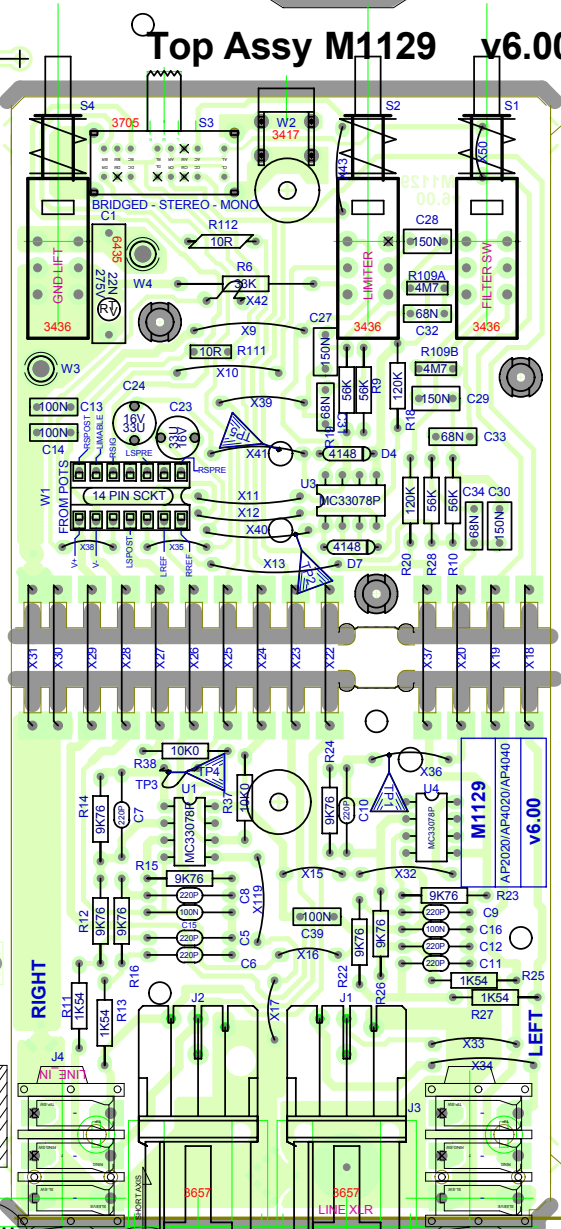

M1129 Database History

MODEL(S):- AP2020 AP4020 AP4040 APM1CE			
#	DATE	VER#	DESCRIPTION OF CHANGE
1	OCT/97	1.00	FIRST PRODUCTION
2	NOV/97	2.00	SWITCH NETS RREF WITH LREF AND RSPRE WITH LSPRE AT 14 PIN CONNECTOR. INPUT TO NONINVERTING
3		.	CHANGE C27, C29, C28, C30 TO 150N
4	DEC/02/97	3.00	PC#5694 PINS 10-12 OF MC2 CONNECTED TO BRG SWT
5	APR/16/98	4.00	ISOLATE PIN OF S3
6	JUL/01/98	4.10	PC#6436 REPLACE R119 (10KΩ) WITH JUMPER X119
7	SEP/06/01	5.00	PC#6873 REDO SOLDERMASK
8	APR/15/05	6.00	CONVERT TO PCAD2002, PC#6944:ROUTE GAUGE,
9	JUL/2005	.	PC#6914:ADD TARGETS
10	AUG-15-2005	.	
11	D	V	N
12	D	V	N
13	D	V	N

M1129 DRILL HISTORY

MODEL(S):- AP2020/AP4020/AP4040/APM1CE			
#	DATE	VER#	DESCRIPTION OF CHANGE
1	APR-03-2003	V06	N
2	AUG-15-2005	V07	CONVERT TO PCAD2002
3	D	V	N
4	D	V	N
5	D	V	N
6	D	V	N

M1129 PENDING CHANGES

MODEL(S):- AP2020/AP4020/AP4040/APM1CE		
#	PC#	PENDING CHANGE
1	PC	X
2	PC	X
3	PC	X
4	PC	X
5	PC	X
6	PC	X

*PLACE IMPLEMENTED CHANGES INTO BOARD HISTORY

PRODUCTION NOTES

- 1 FOR XLR #3657 USE SCREW PT#8829 UP THROUGH THE BOTTOM
- 2 FOR M1129B VX1200/2400/J1/2402 DO NOT STUFF J40 AND J41 ADD WIRES IN BOARD ASSEMBLY

ETCH GUIDE

StepAndRepeat - X4@3.500Y1@0.000

ETCH GUIDE

BlankSize - 14750x7750



CLINCH ORIGIN

INSERT ORIGIN

LONG AXIS



U: M1146V17.PRN

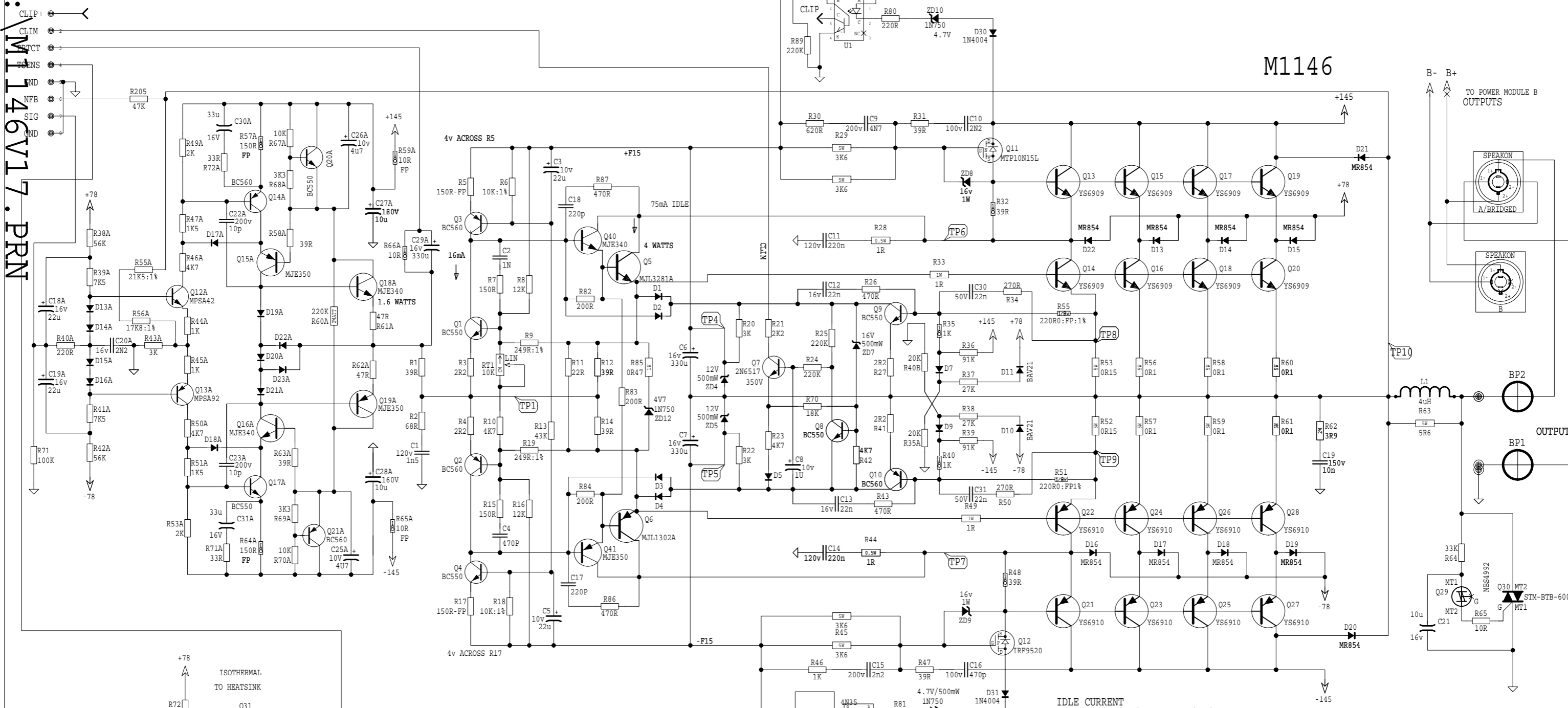

M1146

M1146.SCH DATABASE HISTORY

MODEL(S) :-		AP4040/AM1	
#	DATE	VER#	DESCRIPTION OF CHANGE
1	DEC/97	1.00	FIRST PRODUCTION
2	AUG/26/98	1.10	PC#5806 ADD 33u/16V 33R IN SERIES ACROSS R57A AND ACROSS R64A
3	.	1.20	SPKON JACKS ADDED
4	JUL/12/99	1.30	BRIDGED SPKON B->A
5	AUG/30/99	1.40	PC#6278 ADD C17 R86 AT Q41
6	OCT/12/00	1.50	PC#6429 ADD C18,R87 @ Q40
7	AUG/28/01	1.60	PC#6438 ADD R88,R89 @ U1,U2
8	SEP/18/01	1.70	PC#6517 Q13->Q20 6900->6909 R13,R17 249R->150R R13 27K->43K C18 1N->220P,R87 100R->470R
9	MAY/03/02	.	.
10	.	.	.

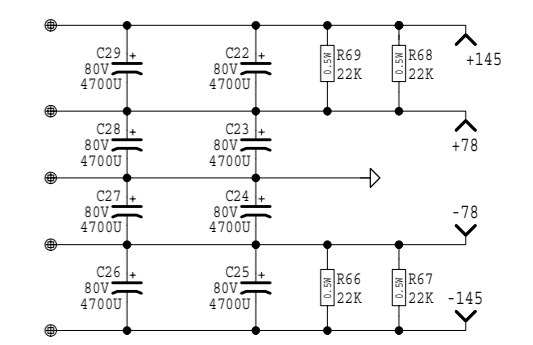
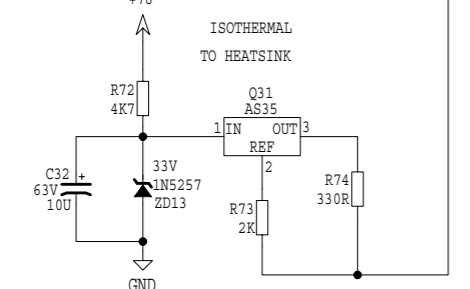
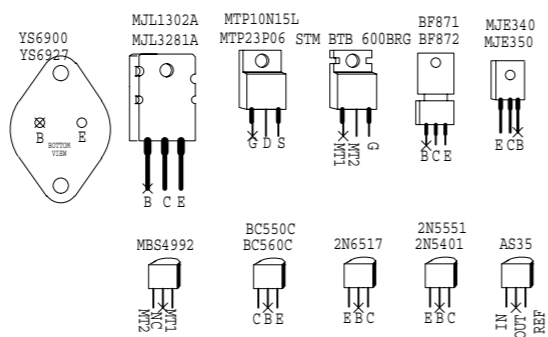

IDLE CURRENT ADJUST FOR 3 TO 5 MILLIVOLTS BETWEEN TESTPOINTS 8 & 9

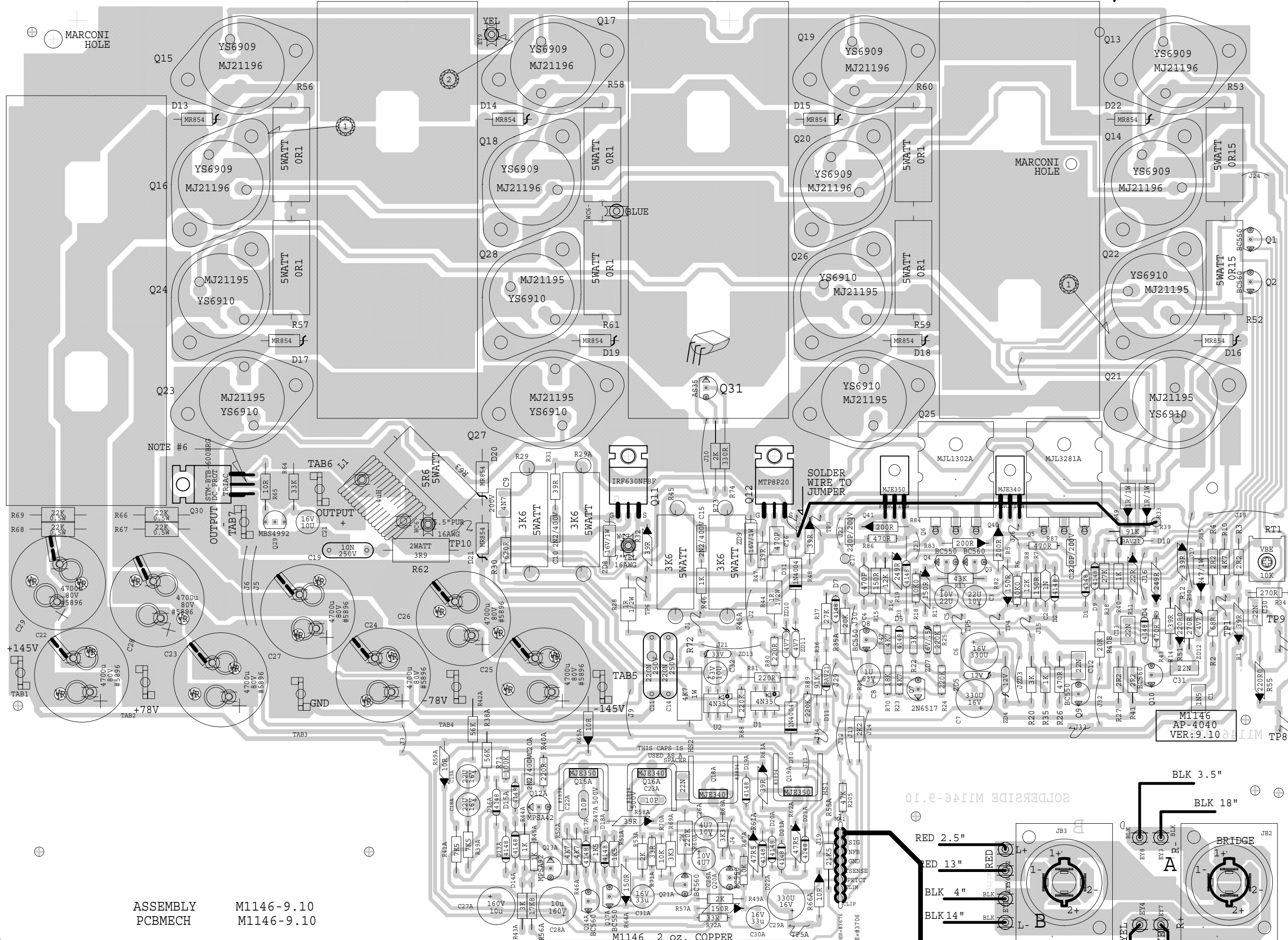

1 PRODUCTION NOTES
MOUNTING DETAILS FOR 5W

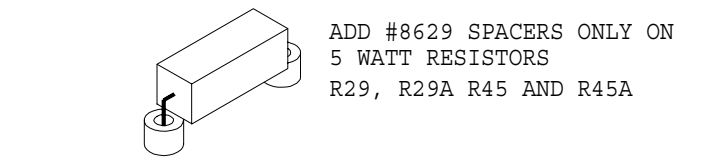

2 MOUNTING HARDWARE FOR Q5, Q6

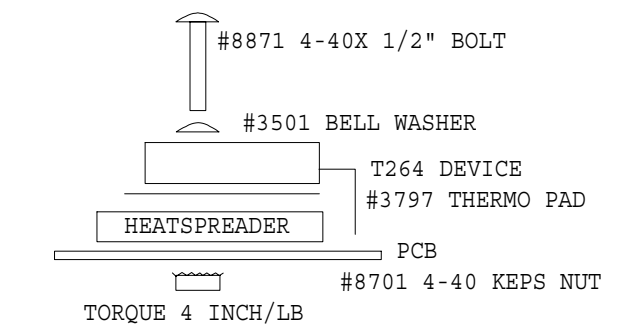

3 MOUNTING HARDWARE FOR Q40, Q41

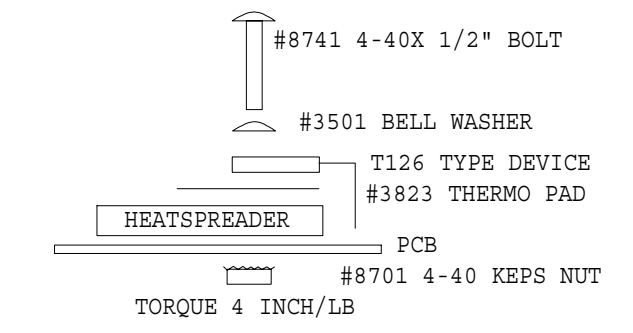

4 MOUNTING HARDWARE FOR Q11, Q12

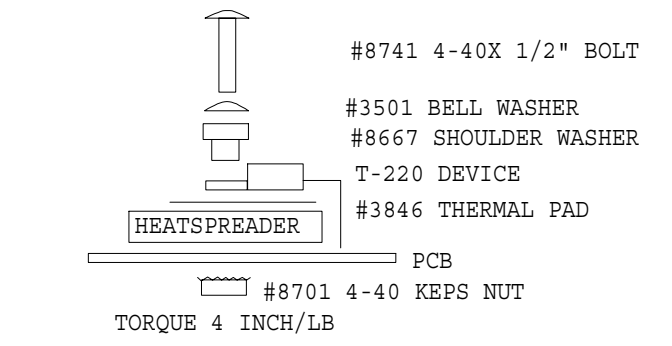

5 MOUNTING HARDWARE FOR TO3 OUTPUTS

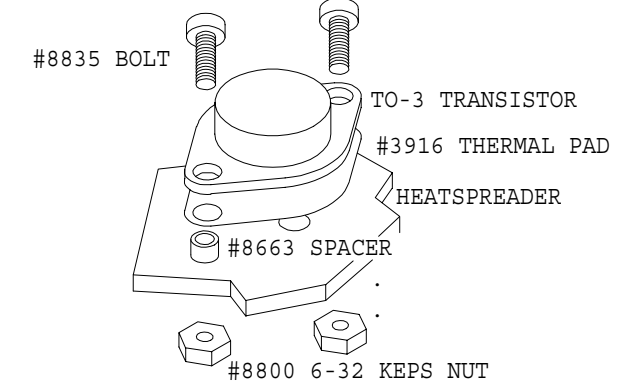

INITIAL TORQUE FOR TO-3'S IS 8 INCH/LB
FINAL TORQUE AFTER HEATSINK HAS COOLED FROM WAVE SOLDER IS 6 INCH/LB

6 USE #XXXX SMALL BODY 1R 1W FOR R33, R49

7 MOUNTING DETAILS FOR Q30 TRIAC

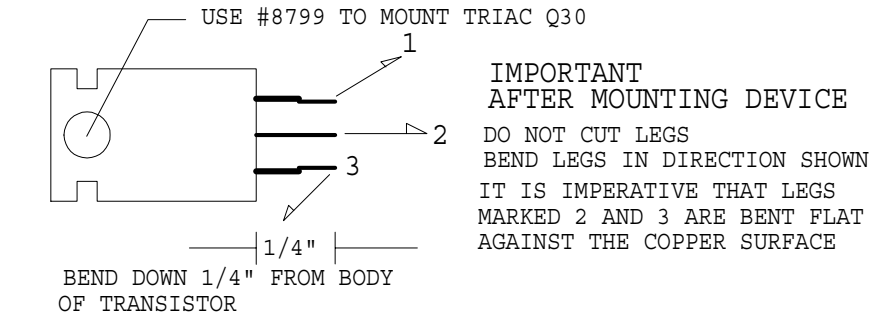

DO NOT STUFF WIRES OR SPEAKON JACKS FOR SERVICE BOARDS

9 Q31 IS HAND INSERTED AND BENT OVER WITH FLAT SIDE UP AS SHOWN.

10

M1146.PCB DATABASE HISTORY			M1146.PCB DATABASE HISTORY				
#	DATE	VER#	DESCRIPTION OF CHANGE	#	DATE	VER#	DESCRIPTION OF CHANGE
1	FEB/12/98	1.00	RENAMED M1126A->M1146	1	SEP/18/01	8.00	PC#6438 /ADD R88,R89 @ U1,U2
2	JUN/19/98	1.01	PC#5767 C10/C15/C20A 2N2 TO PT#5427	2	MAY/03/02	8.10	PC#6517 Q13->Q20 #6900->6909
3	JUL/45/98	1.02	PC#5798 R72 4K7 1/2W->4K7 1W	3			#6927->6910 R5,R17 249R->150R
4	SEP/10/98	2.00	PC#5806 ADD 33R 33u/16V ACROSS_R57A R64A C30A/R72A C31A/R71A	4			R13 27K->43K,C18 1N->220P
5				5			R87 100R->470R
6	JAN/27/99	3.00	PC#5908 U1,U2 4N35->TLP621	6	MAY/16/03	8.20	PC#6607 C10,C15,C20A #5427->#5208
7	JUL/08/99	4.00	SPKON JACKS RE-CONFIGURED	7	FEB/09/04	8.30	PC#6658 MOVE 1 BREAKAWAY AND ROUTING
8	AUG/12/99	5.00	CORRECT ERROR IN SPKONS	8	MAY/10/05	9.00	REDO SOLDERMASK
9	OCT/12/00	6.00	PC#6278 ADD R86-C17 AT Q41	9	APR/24/06	9.10	PC#7007 MAC224-4 TO STM BTB 600BRG
10			PC#6083 REDO GND TRACKS	10	MAY/02/06		PC#7083 MPT10N15L TO IRF630NPBF
11	AUG/28/01	7.00	PC#6429 ADD R87,C18 AT Q40	11			

BLANK SIZE=14.750"X10.850"

505 COBBLER

L1116912.FRM

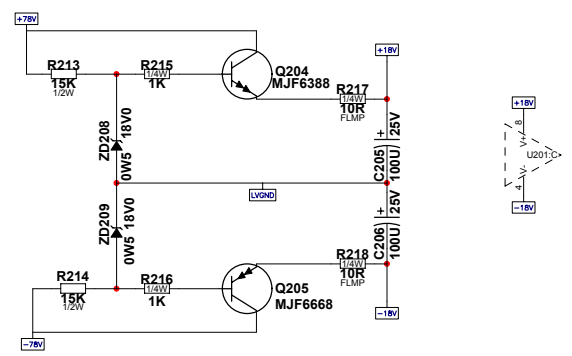
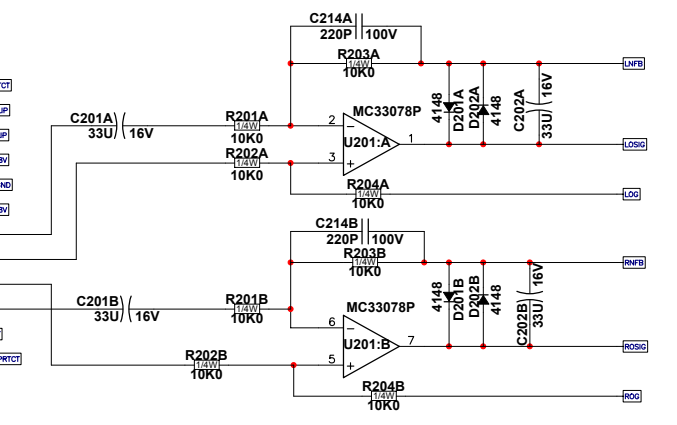
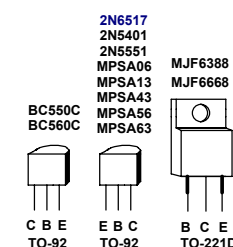
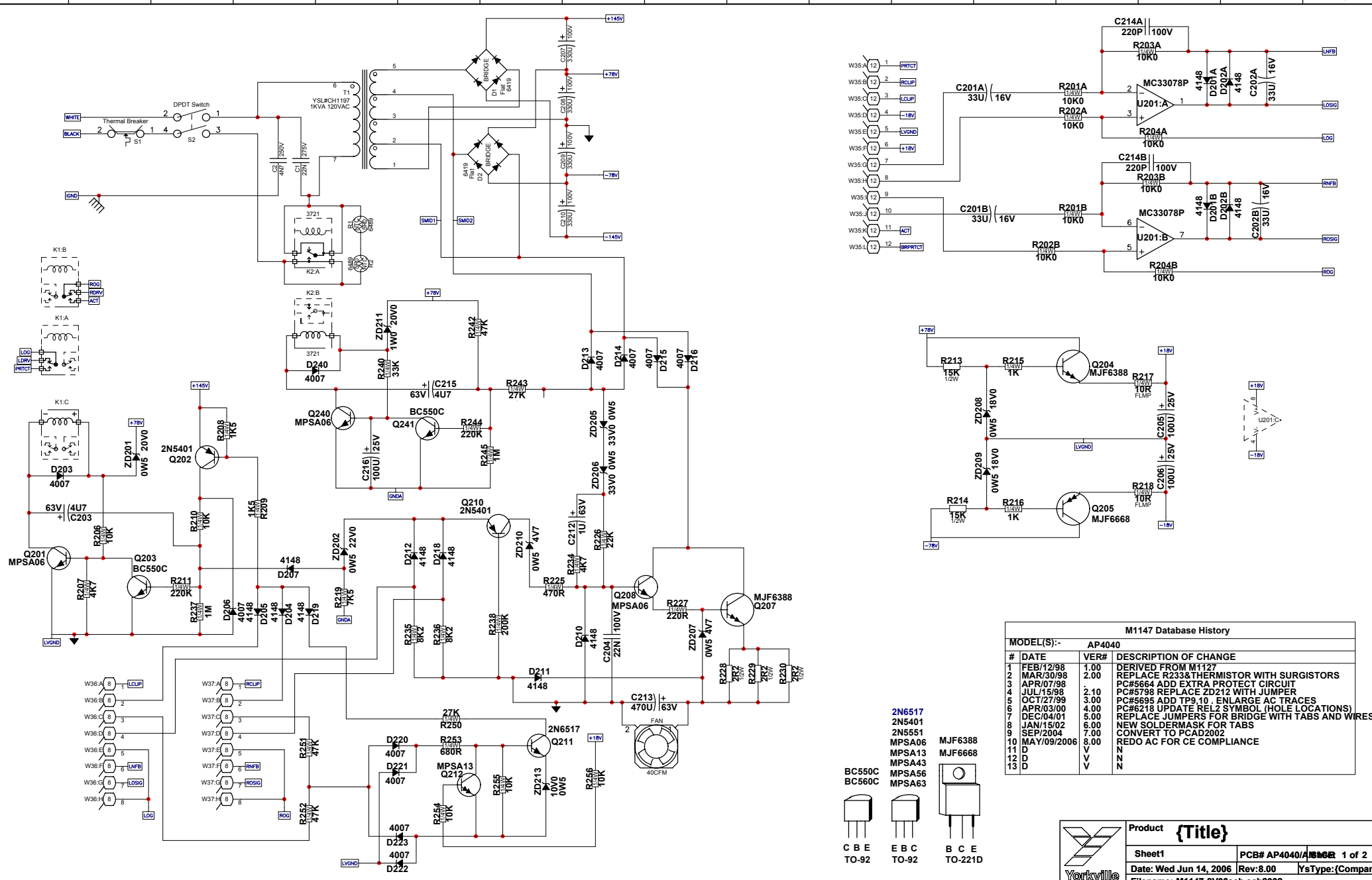

M1147 Database History			
MODEL(S):-	AP4040	VER#	DESCRIPTION OF CHANGE
1	FEB/12/98	1.00	DERIVED FROM M1127
2	MAR/30/98	2.00	REPLACE R233&THERMISTOR WITH SURGISTORS
3	APR/07/98	3.00	PC#5664 ADD EXTRA PROTECT CIRCUIT
4	JUL/15/98	2.10	PC#5798 REPLACE ZD212 WITH JUMPER
5	OCT/27/99	3.00	PC#5695 ADD TP9_10 - ENLARGE AC TRACES
6	APR/03/00	4.00	PC#6218 UPDATE REL2 SYMBOL (HOLE LOCATIONS)
7	DEC/04/01	5.00	REPLACE JUMPERS FOR BRIDGE WITH TABS AND WIRES
8	JAN/15/02	6.00	NEW SOLDERMASK FOR TABS
9	SEP/2004	7.00	CONVERT TO PCAD2002
10	MAY/09/2006	8.00	REDO AC FOR CE COMPLIANCE
11	D	V	N
12	D	V	N
13	D	V	N



BlankSize - 14150 x 7350

ETCH GUIDE

00V8 7411M

Pcb Mech M1147 8V00

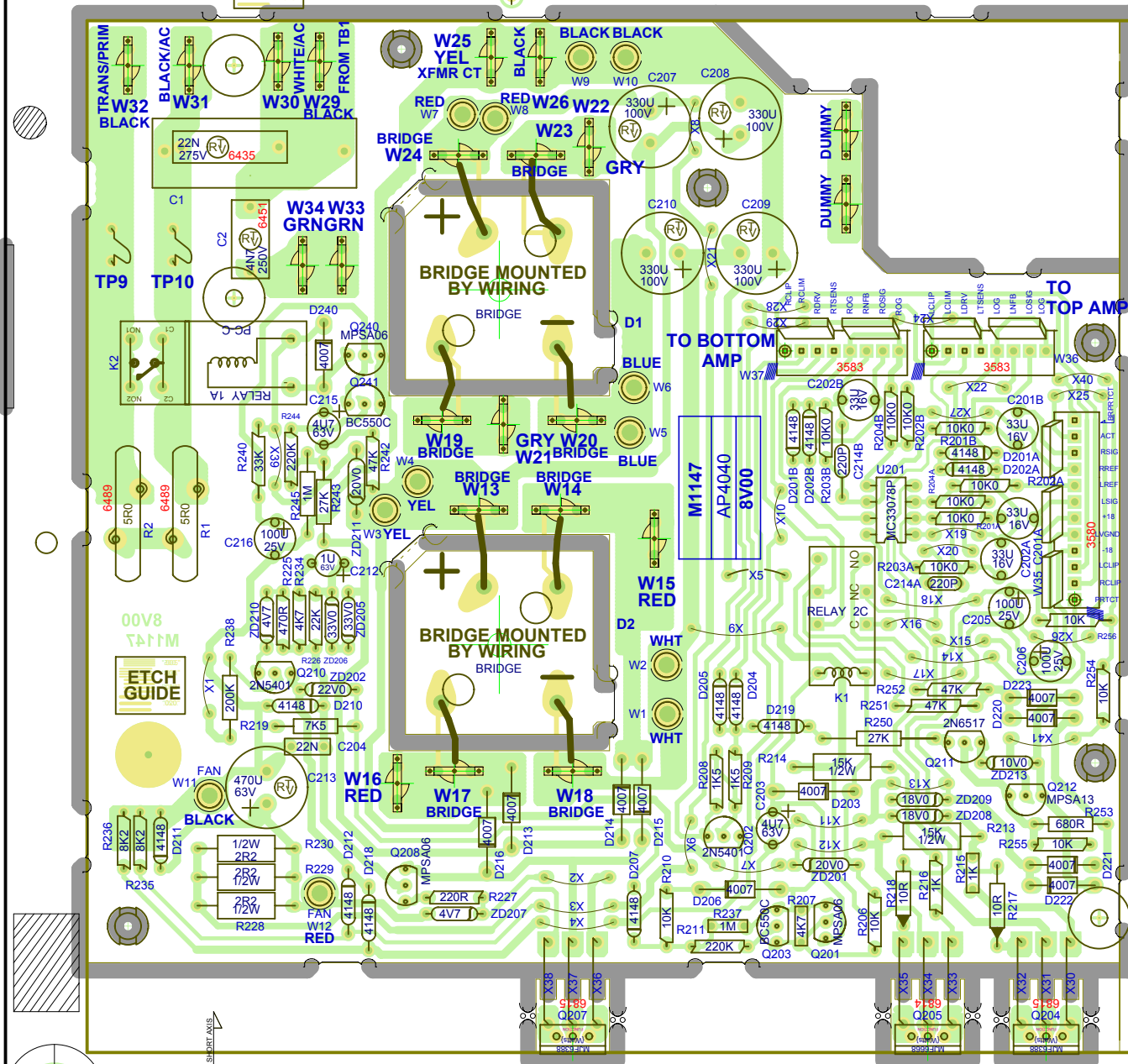

ETCH GUIDE

00V8 7411M

CLINCH ORIGIN

INSERT ORIGIN

Top Assy M1147 8V00



SEE LAYOUT DOCUMENTATION





SEE LAYOUT DIAGRAM



M1147 Database History

#	DATE	VER#	DESCRIPTION OF CHANGE
MODEL(S):- AP4040			
1	FEB/12/98	1.00	DERIVED FROM M1127
2	MAR/30/98	2.00	REPLACE R233&THERMISTOR WITH SURGISTORS
3	APR/07/98	.	PC#5664 ADD EXTRA PROTECT CIRCUIT
4	JUL/15/98	2.10	PC#5798 REPLACE ZD212 WITH JUMPER
5	OCT/27/99	3.00	PC#5695 ADD TP9,10 . ENLARGE AC TRACES
6	APR/03/00	4.00	PC#6218 UPDATE REL2 SYMBOL (HOLE LOCATIONS)
7	DEC/04/01	5.00	REPLACE JUMPERS FOR BRIDGE WITH TABS AND WRES
8	JAN/15/02	6.00	NEW SOLDERMASK FOR TABS
9	SEP/2004	7.00	CONVERT TO PCAD2002
10	9-MAY-2006	8.00	REDO AC FOR CE COMPLIANCE
11	D	V	N
12	D	V	N
13	D	V	N

Mnnnn Drilling History

#	DATE	VER#	DESCRIPTION OF CHANGE
MODEL(S):- {MODEL}			
1	D	V	N
2	D	V	N
3	D	V	N
4	D	V	N
5	D	V	N
6	D	V	N
7	D	V	N
8	D	V	N
9	D	V	N
10	D	V	N
11	D	V	N
12	D	V	N
13	D	V	N

PRODUCTION NOTES:

- FOR C1 USE 22N FOR NORTH AMERICAN AND 680N FOR EURO.
- ADD RTV UNDER RELAY AND BEND LEADS FLAT TO PCB.

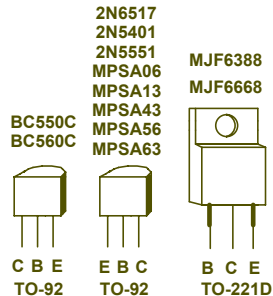

SERVICE BULLETIN

AP4020 &
AP4040

Quick Fix for M1146 & M1126

To speed up the servicing of the AP4020 or AP4040 on your bench, Yorkville Sound's service department has developed a method to replace the components most likely to fail when a M1146 amplifier board requires service.

This Quick Fix kit contains the procedure, assembly drawings, and components to perform the Quick Fix to a M1146 or M1126 board.

It should be understood that the person using this procedure knows how to test resistors, diodes, and transistors to determine if they are defective. This procedure is not intended to be a substitute for one's lack of electronic capability.

Before starting, look at the board for repair and locate the version number. It is very important that you follow the procedure for the appropriate circuit board version number.

A complimentary service manual for the AP4020 power amplifier is supplied with this M1146KIT.

- STEP 1.** Locate the assembly drawing for the version number printed on the M1146 or M1126 circuit board to be serviced.
- STEP 2.** Remove all of the transistors coloured RED on the assembly drawing.
- STEP 3.** Measure and remove any of the diodes coloured BLUE on the assembly drawing that may be damaged. Replace a 1N4732A 1W 4V7 zener (#6459) ZD12 along with a series 0.5 ohm R85 resistor.
- STEP 4.** Rotate the trim pot RT1 fully counter - clockwise as in figure 1. Inspect and replace any resistors that look burnt. Measure all of the resistor values coloured YELLOW on the assembly drawing. The value that you measure may not be exactly what is shown on the assembly drawing but if the resistor doesn't look damaged it should measure within + or - 5% of the printed value.

SERVICE BULLETIN

AP4020 &
AP4040

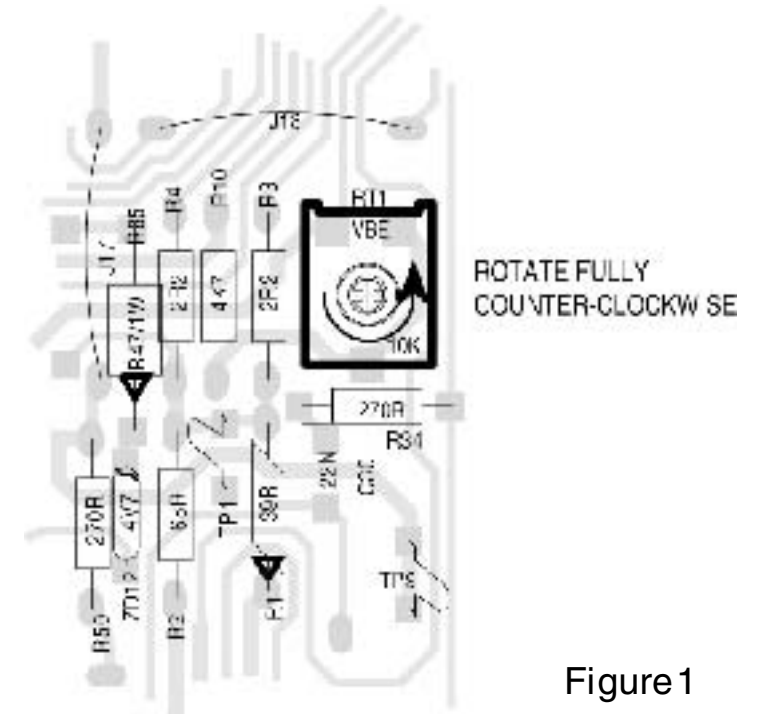

Figure 1

- STEP 5.** Measure the resistor coloured GREEN. The measured value should measure within + or - 5% value listed in the table below. Replace any resistor that measured beyond the + or - 5% value listed in the table below.

RESISTOR NUMBER	PRINTED VALUE	CORRECT MEASURED VALUE
R10	4K7	-5% 3K08 +5% 3K41



Canada
Voice: (905) 837-8481
Fax: (905) 837-8746

U.S.A.
Voice: (716) 297-2920
Fax: (716) 297-3689

www.yorkville.com

Yorkville Sound
550 Granite Court
Pickering, Ontario
L1W-3Y8 CANADA

Yorkville Sound Inc.
4625 Witmer Industrial Estate
Niagara Falls, New York
14305 USA



Canada
Voice: (905) 837-8481
Fax: (905) 837-8746

U.S.A.
Voice: (716) 297-2920
Fax: (716) 297-3689

www.yorkville.com

Yorkville Sound
550 Granite Court
Pickering, Ontario
L1W-3Y8 CANADA

Yorkville Sound Inc.
4625 Witmer Industrial Estate
Niagara Falls, New York
14305 USA

SERVICE BULLETIN

AP4020 &
AP4040

STEP 6. Measure across the pair of test points shown in the component layout listed in the table below. If the measured value is not within + or - 10% of the value listed in the table then replace the resistors shown in the table below.

TEST POINTS	LAYOUT REFERENCE	CORRECT MEASURED VALUE	LAYOUT REFERENCE
R10	4K7	-10% 15ohm +10% 17ohm 19ohm	R11, R12, R14

STEP 7. Measure the resistors coloured ORANGE. Since the value of these resistors is 0.1 ohm, your ohmmeter will measure the higher series resistance of the test leads if the resistor is OK. If the resistor is damaged your ohmmeter will read a very high resistance (an open circuit). Replace any damaged resistors.

STEP 8. Measure the output TO-3 transistors (Q13 to Q28) to determine if any are damaged. Mark any damaged transistors with a marking pen.

STEP 9. Replace any output transistors that you have marked as being damaged. Replace any diodes that you have found to be damaged. Replace all of the red transistors that were removed.

STEP 10. Inspect the traces on the circuit board for any that have 'fused' open or looklike they got very hot. Bridge and solder a piece of wire over any damaged traces.

AFTER YOU HAVE REPLACED ALL OF THE NECESSARY COMPONENTS INSPECT THE REPAIRED BOARD FOR ANY MISSING PARTS, CORRECT VALUES IN THE CORRECT POSITION AND THAT ALL COMPONENTS ARE SOLDERED.

Canada

Voice: (905) 837-8481
Fax: (905) 837-8746

U.S.A.

Voice: (716) 297-2920
Fax: (716) 297-3689

www.yorkville.com

Yorkville Sound
550 Granite Court
Pickering, Ontario
L1W-3Y8 CANADA

Yorkville Sound Inc.
4625 Witmer Industrial Estate
Niagara Falls, New York
14305 USA



SERVICE BULLETIN

AP4020 &
AP4040

Testing Repaired Circuit Boards

Now that you have rebuilt the M1146 or M1126 circuit board. It is just as important to properly power up the board. If the sinewave doesn't look right check the signal at test point (1) to ensure that the voltage amplifier isn't distorting the signal. If there is still a damaged part on the board instantly turning it on could blow up the board and you would be back where you started.

Connect the power wires and ground to the power supply. Connect a digital multimeter to test pins 8 and 9 to measure the bias quiescent current and place a scope probe on the speaker output. Be sure to turn the quiescent current trimpot RT1 fully counter clockwise.

Now using a variac slowly turn up the AC main voltage while monitoring the quiescent voltage and the speaker output trace on the scope. Watching these two test points is a good indicator of the health of the board. If you have a second multimeter connect it up from the speaker output to test point 4 or 5. As you variac up also check these DC battery voltages to ensure that they both increase in voltage to approximately +12 or -12 vdc.

If the board looks OK after variacing up to 120vac then slowly turn up the bias (RT1 trimpot) to obtain 3 to 5 millivolts of bias voltage on test points 8 and 9. Check the speaker output with a 1KHZ sinewave with no load. If this looks good place the minimum rated load (4 Ohm for M1126, 2 Ohm for M1146) on the speaker output and increase the sinewave amplitude to the point of clipping. If the signal looks free of oscillation, place a short across the speaker posts. The amplifier should go into protect mode after 1/10 of a second. Remove the short and the sinewave will appear 6 seconds later.

Reassemble the complete amplifier and run just clipping music or pink noise into the minimum rated speaker load for that model of amplifier. Let the amplifier heat up for 20 minutes. This will check the thermal mounting of the transistors and for any weak parts not caught during troubleshooting.

If the amplifier passes this test the product is ready to return to the customer.

Canada

Voice: (905) 837-8481
Fax: (905) 837-8746

U.S.A.

Voice: (716) 297-2920
Fax: (716) 297-3689

www.yorkville.com

Yorkville Sound
550 Granite Court
Pickering, Ontario
L1W-3Y8 CANADA

Yorkville Sound Inc.
4625 Witmer Industrial Estate
Niagara Falls, New York
14305 USA



M1146 KIT

BLANK SIZE=14.400"X7.700"

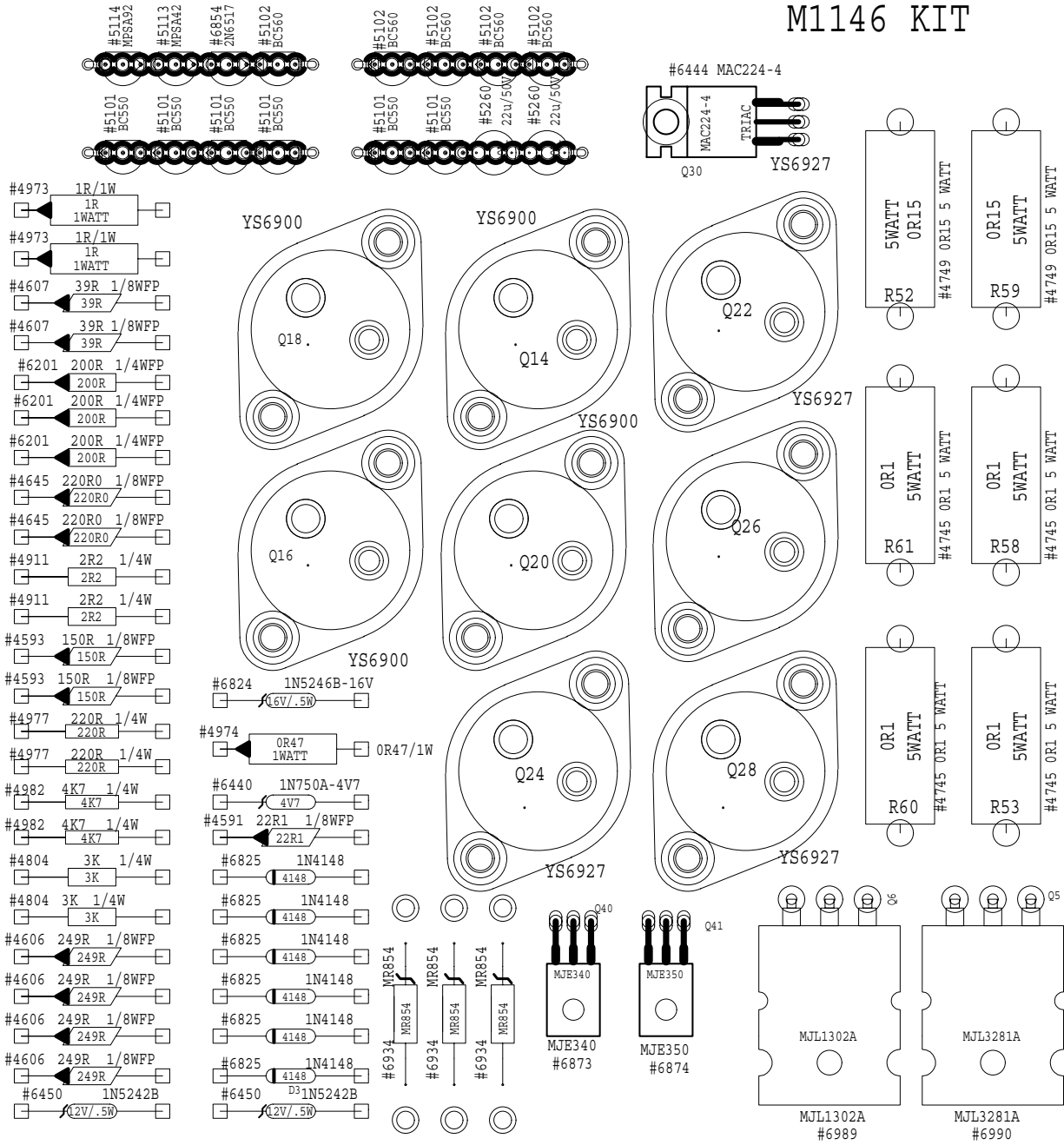

ASSEMBLY M1146-KIT
PCBMECH M1146-KIT

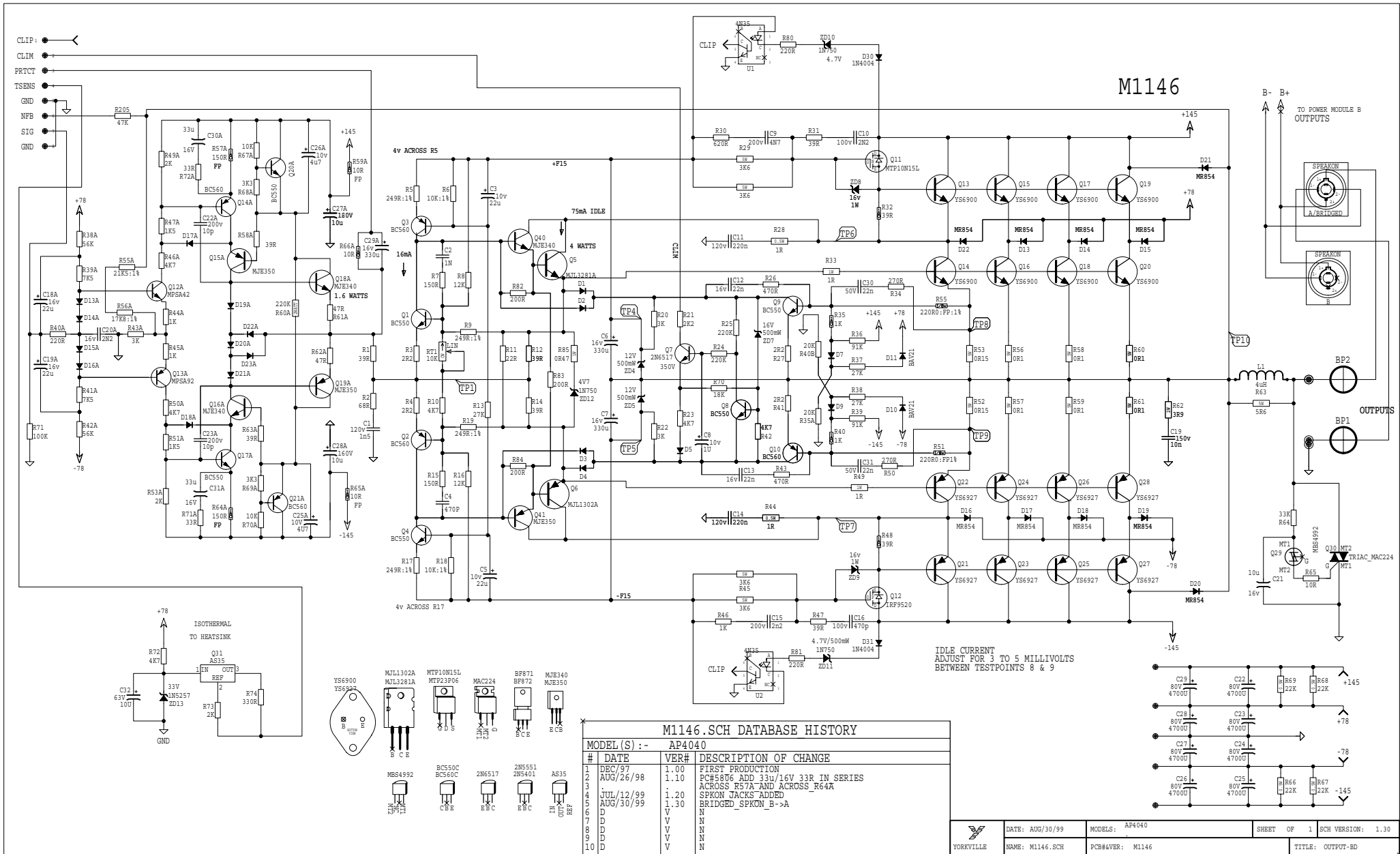

M1146.SCH DATABASE HISTORY

#	DATE	VER#	DESCRIPTION OF CHANGE
MODEL(S) :- AP4040			
1	DEC/97	1.00	FIRST PRODUCTION
2	AUG/26/98	1.10	PC#5806 ADD 33V/16V 33R IN SERIES
3			ACROSS R57A AND ACROSS_R64A
4	JUL/12/99	1.20	SPKON JACKS ADDED
5	AUG/30/99	1.30	BRIDGED_SPKON B->A
6			
7			
8			
9			
10			

REF: 0545PTTFF

M1146

AP-4040

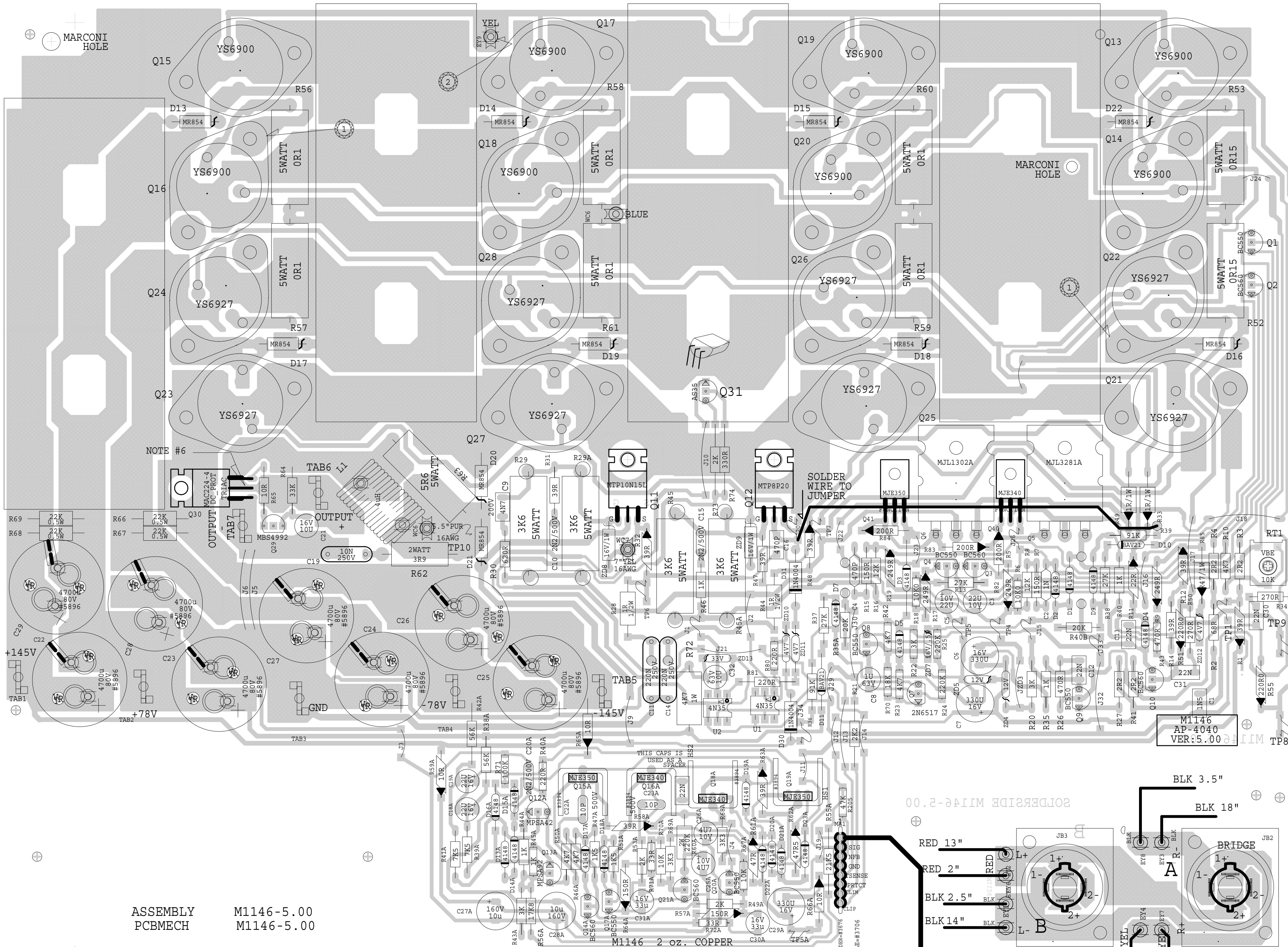

3oz. COPPER

"028.01X"02V.41=12.12 W/ALIB
BLANK SIZE=14.750"X10.850"

ASSEMBLY M1146-5.00
PCBMECH M1146-5.00

M1146.PCB DATABASE HISTORY			
MODEL(S) :- AP4040			
#	DATE	VER#	DESCRIPTION OF CHANGE
1	FEB/12/98	1.00	RENAMED M1126A->M1146
2	JUN/19/98	1.01	PC#5767 C10/C15/C20A 2N2 TO PT#5427
3	JUL/45/98	1.02	PC#5798 R72 4K7 1/2W->4K7 1W
4	SEP/10/98	2.00	PC#5806 ADD 33R 33u/16V ACROSS_R57A R64A C30A/R72A C31A/R71A
5	JAN/27/99	3.00	PC#5908 U1,U2 4N35->TLP621
6	JUL/08/99	4.00	SPKON JACKS RE-CONFIGURED
7	AUG/12/99	5.00	CORRECT_ERROR_IN_SPKONS
8	D	V	N
9	D	V	N
10	D	V	N
11	D	V	N

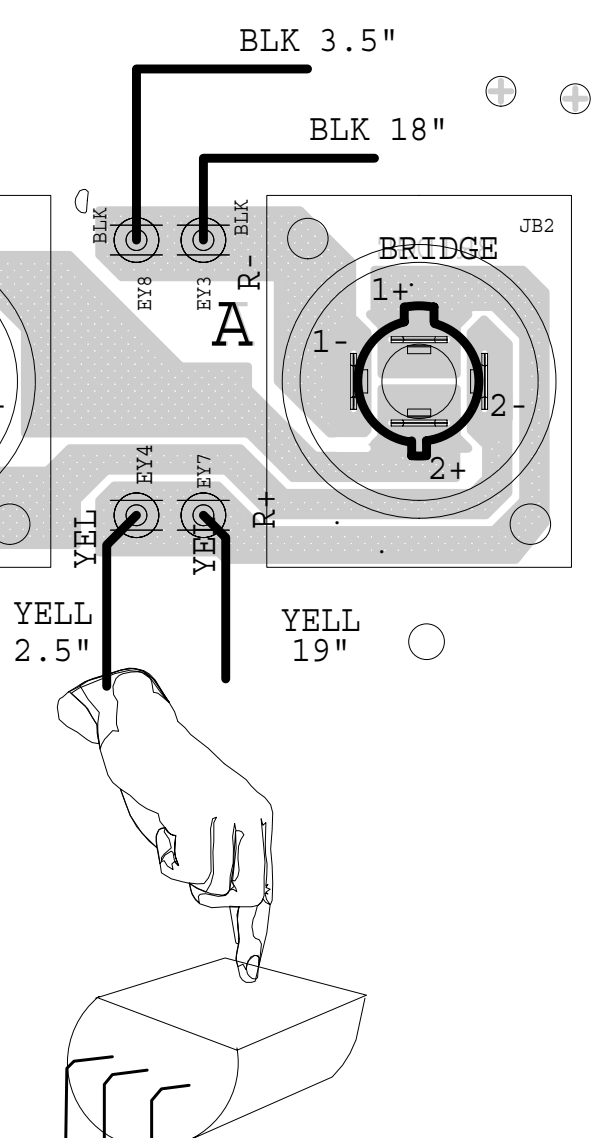
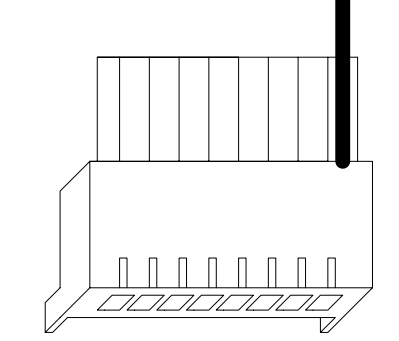

AP4040CE AC WIRING JAN,26,99
SHOWN WIRED FOR 230V

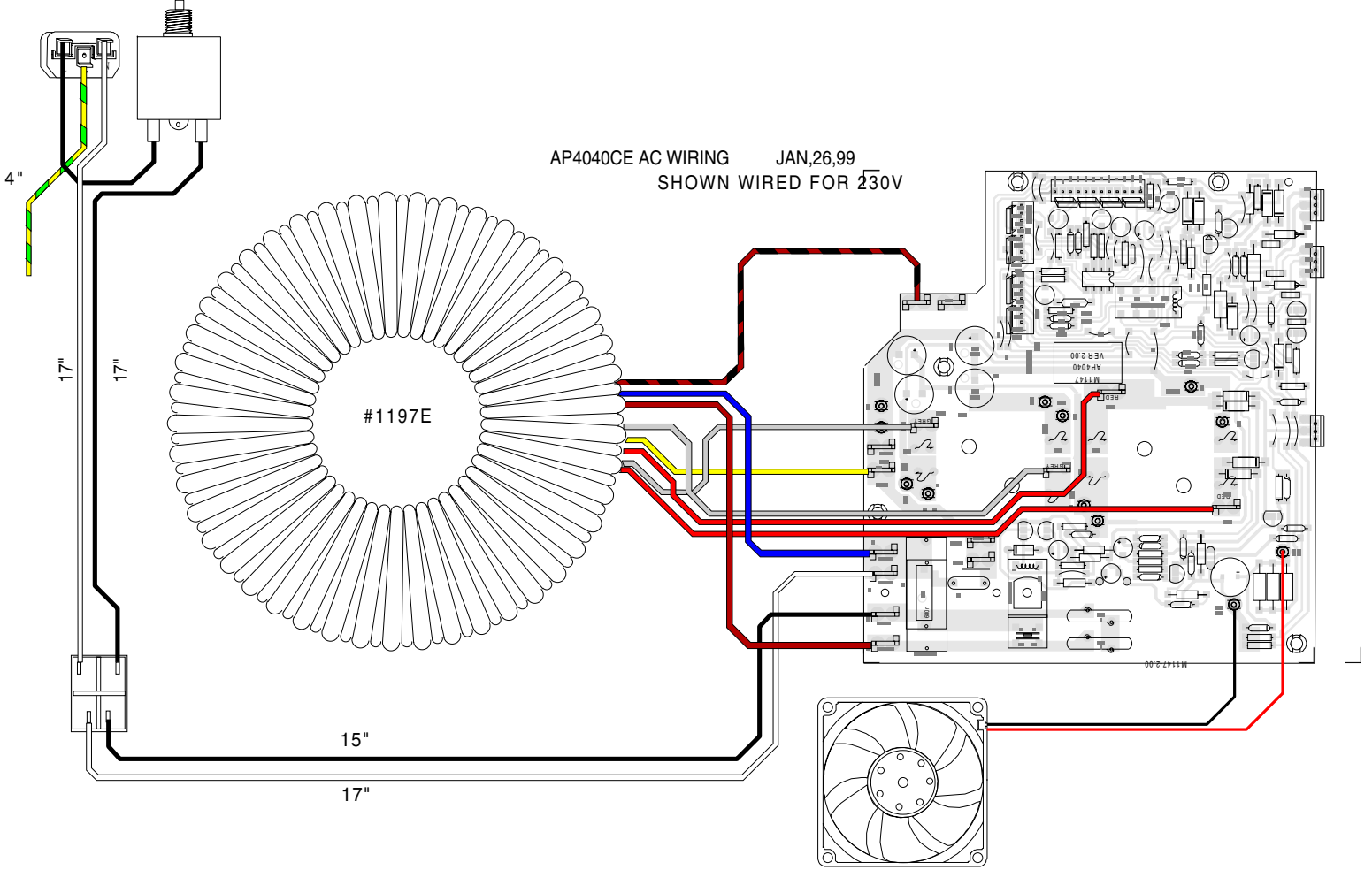

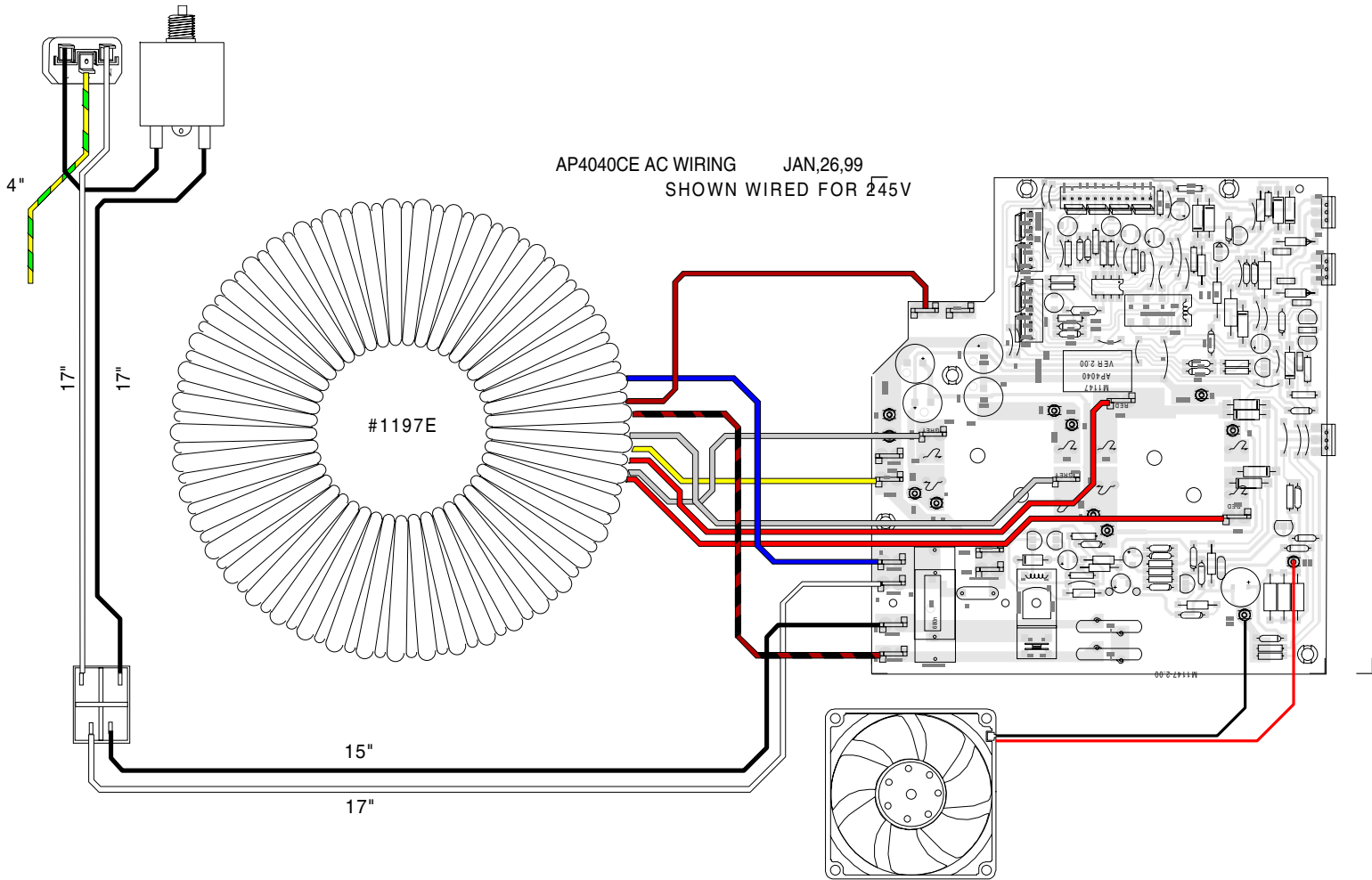

AP4040CE AC WIRING JAN,26,99
SHOWN WIRED FOR 245V

#1197E

M1187
AP4040
VER 2.00

M1147-2-00

4"

17"

17"

15"

17"